

SHOWER CHANNEL FOR WALK-IN TILED SHOWERS WITH REVERSIBLE GRATING



Nicoll
by aliaxis



THE IDEAL SHOWER CHANNEL FOR TILED SHOWERS.

- > A stainless-steel channel body and a stainless steel grating,
- > Two available lengths: 500 mm or 700 mm,
- > Reversible: to be tiled or stainless steel finish.
- > A performing drainage system: Nicoll Turboflow® waste.
- > Two included connectors: an elbow for bonding Ø 40/50 mm + an adapter Ø 40 x 50 mm

FUNCTION

- The shower channel is used to drain tiled showers.

DESCRIPTION

- The product consists of a stainless-steel channel body and a stainless steel grating, length 500 mm or 700 mm, reversible (to be tiled or stainless steel finish). The drainage is made through a Turboflow® waste.
- Two connectors supplied : a Ø 40/50 mm elbow & a short Ø 40x50 mm adapter.

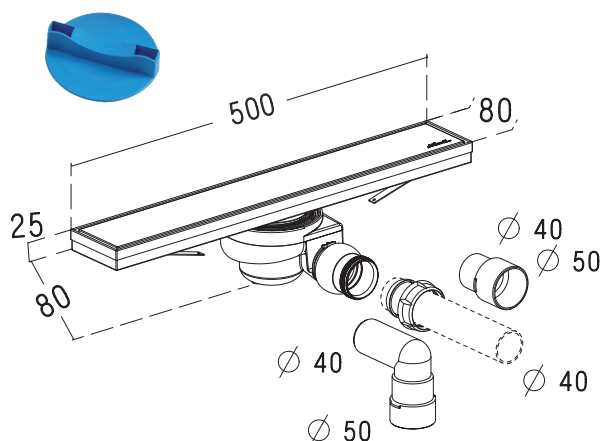

TECHNICAL FEATURES

- Channel and grating made of stainless steel grade 304.
- Overall height (channel body and waste): 80 mm.
- Waste TurboFlow® in polypropylene - Flow rate: 0,65 l/s under 15 mm water load.
- Water seal: 50 mm height.
- ABS swivel horizontal outlet (to be glued or push fit).
- ABS short adapter for Ø50 mm horizontal outlet (to be glued or push fit).
- Ø 40/50 mm ABS elbow connector, for a vertical outlet (to be glued, or push fit).

IMPLEMENTATION

- The installation blue key acts as a protection plug during installation to protect the soil pipe.
- Connection to the soil pipe : by solvent welding or push-fit.
- A waterproofing under screed must be planned.

MAINTENANCE

Remove and clean the inner trap on a regular basis.
Use a non aggressive cleaner and soft cloth to avoid scratches on the grating.

DIMENSIONS

	Description	length (mm)	Code Nr
	CS51S – Shower Channel Stainless steel - L 500 mm	500	0205558
	CS71S – Shower Channel Stainless steel - L 700 mm	700	0205557

ISO 9001
ISO 14001
BUREAU VERITAS
Certification



Nicoll
by aliaxis

Head office and factories: 37, rue Pierre et Marie Curie - BP 10966 - 49309 CHOLET cedex - Phone: +33 (0)2 41 63 73 83
SAS (PLC) with a working capital of 7 683 431 E - 060 200 128 RCS Angers