

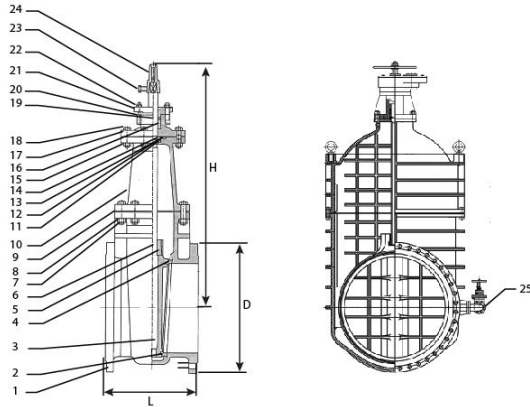

METAL-SEATED GATE VALVE



Parts List & Materials

No.	Component	Material	Standard Ref.
1	Body	Ductile Iron	BS EN 1563
2	Seat Sealing	EPDM	MS 672 / BS EN 681
3	Wedge	Ductile Iron	BS EN 1563
4	Wedge Sealing	Gun Metal	BS 1400
5	Stem Nut	Gun Metal	BS 1400
6	Stem	Stainless Steel	BS EN 10088-3
7	Gasket	EPDM	BS EN 681
8	Nut	Carbon Steel	BS 4190
9	Bolt	Carbon Steel	BS 4190
10	Bonnet	Ductile Iron	BS EN 1563
11	Back Seat	EPDM	BS EN 681
12	Washer	Stainless Steel	BS EN 10088-3
13	Bearing	Gun Metal	BS 1400
14	O-Ring	EPDM	BS EN 681
15	Packing Box	Ductile Iron	BS EN 1563
16	O-Ring	EPDM	BS EN 681
17	Collar	Gun Metal	BS 1400
18	Gland	Ductile Iron	BS EN 1563
19	Cap	Ductile Iron	BS EN 1563
20	Bolt	Carbon Steel/ Stainless Steel	BS 4190/ BS EN 10088-3
21	Nut	Carbon Steel/ Stainless Steel	BS 4190/ BS EN 10088-3
22	Bolt	Carbon Steel/ Stainless Steel	BS 4190/ BS EN 10088-3
23	Bolt	Carbon Steel/ Stainless Steel	BS 4190/ BS EN 10088-3
24	Nut	Carbon Steel/ Stainless Steel	BS 4190/ BS EN 10088-3
25	By-Pass Valve	Ductile Iron	BS EN 1563

Specifications & Parameters Chart

DN (mm)	L (mm)	H (mm)	D (mm)
50	178	290	165
65	190	350	185
80	203	387	200
100	229	433	220
150	267	480	285
200	292	590	340
250	330	678	400
300	356	768	455
350	381	1118	520
400	406	1194	580
450	432	1297	640
500	457	1382	715
600	508	1580	840
700	610	1087	910
800	660	2025	1025
900	711	2204	1125
1000	813	2436	1255
1200	960	2726	1485
1400	960	3090	1685

Note: Technical data provided in this brochure is indicative only and may be subject to change without prior notice.



SLUICE VALVES

NON-RISING STEM DOUBLE FLANGED RESILIENT-SEATED & METAL-SEATED GATE VALVES FOR SYSTEM ISOLATION

KEKALBOLEH SDN BHD
(199901021248/496148-K)
Lot No. 7, Lorong Perindustrian Kolombong Jaya,
Pusat Perindustrian Kolombong Jaya,
Mile 5.5, Jalan Kolombong,
88450 Kota Kinabalu, Sabah.
Tel/WhatsApp: 088-385555 / 013-8867570
Website: kekalboleh.com



The Brand Of Reliability

LYE MANUFACTURING SDN.BHD. (197701001852 (32836-H))

Manufacturer of Valves, Hydrants, Joints, Fittings & Manhole Covers

Lot 1844, Jalan KPB 8, Kampung Baru Balakong, 43300 Kajang, Selangor Darul Ehsan, Malaysia.

FACTORY Tel: 603 - 8961 1623 Fax: 603 - 8961 1092 SALES Tel: 603 - 6140 3131(Hunting Line) Fax: 603 - 6140 5858

EMAIL: enquiry@lye.com.my



In Brief

- ▶ LYE Non-Rising Stem Gate Valves or Commonly Known as Sluice Valves is Designed for Complying Heavy Duty Works in Water, Wastewater & Industrial Work Applications
- ▶ Multi-Turn Isolating Valves with Drop-Tight Sealing (Rubber Covered) & Watertight Bearing (Metal Surface) Wedge Gate Discs for System Operation & Maintenance
- ▶ Straight Through Bore Valves Design for Ensuring Optimum Flow Characteristics Through the Valve Thereby Reducing Head Loss
- ▶ Internal & External Body is Coated with Polymeric Coating-Fusion Bonded Epoxy Coating for Excellent Resistance to Corrosion, Abrasion, Wear & Tear
- ▶ Bolts Sealed with Wax to Prevent Corrosion
- ▶ Working Pressure : 10/16 bar
- ▶ Shell Test Pressure: 15/24 bar
- ▶ Seat Test Pressure : 11/17.6 bar
- ▶ Coating : Fusion Bonded Epoxy
- ▶ Sealing : EPDM

Standards

- ▶ Design : BS 5163 & BS EN 1171
- ▶ Test : BS EN 1074
- ▶ Flange : BS EN 1092-2
- ▶ Face to Face : EN 558-1, Series 3
- ▶ Top Flanged : ISO 5210

Features

- ▶ Range of Resilient Seated Valve Sizes : DN50 to DN600
- ▶ Range of Metal-Seated Valve Sizes : DN50 to DN1400
- ▶ Design for Accommodating Various Type of Actuators, from Manual Actuators to Electric & Pneumatic Automatic Actuators
- ▶ Standard Cap Top & Option with Handwheel
- ▶ Option with Complete By-Pass Valve (DN450 - DN1400)
- ▶ For Metal-Seated Option with Complete Handwheel with Spur Gear (\geq DN350)



With Handwheel

Standard Cap Top

Top Flanged For Actuation

Resilient-Seated Gate Valves



Option : Complete with By-Pass Valve

Metal-Seated Gate Valves



RESILIENT-SEATED GATE VALVE

RESILIENT SEATED NON-RISING STEM GATE VALVE

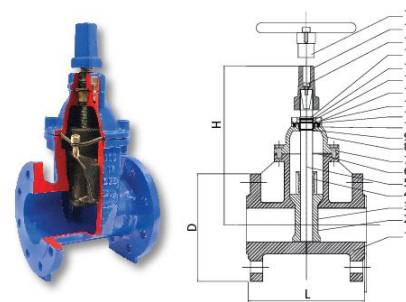

GATE VALVE FOR ACTUATION (RESILIENT-SEATED)

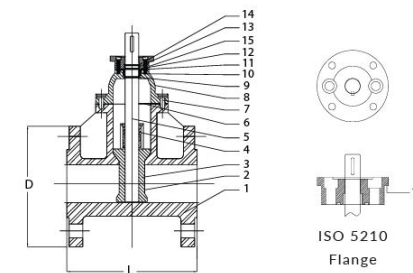

Parts List & Materials

No.	Component	Material	Standard Ref.
1	Body	Ductile Iron	BS EN 1563
2	Rubber Coating	EPDM	MS 672 / BS EN 681
3	Wedge	Ductile Iron	BS EN 1563
4	Stem Nut	Gun Metal	BS 1400
5	Stem	Stainless Steel	BS EN 10088-3
6	Gasket	EPDM	BS EN 681
7	Cap Screw	Stainless Steel	BS EN 10088-3
8	Bonnet	Ductile Iron	BS EN 1563
9	O-Ring	EPDM	BS EN 681
10	Trust Collar	Gun Metal	BS 1400
11	O-Ring	EPDM	BS EN 681
12	O-Ring	EPDM	BS EN 681
13	Bush	Nylon	ASTM D4066
14	O-Ring	EPDM	BS EN 681
15	Gland	Ductile Iron	BS EN 1563
16	Dust-Proof Cover	EPDM	BS EN 681
17	Bolts	Stainless Steel	BS EN 10088-3
18	Cap	Ductile Iron	BS EN 1563
19	Handwheel	Ductile Iron	BS EN 1563

Parts List & Materials

No.	Component	Material	Standard Ref.
1	Body	Ductile Iron	BS EN 1563
2	Rubber Coating	EPDM	MS 672 / BS EN 681
3	Wedge	Ductile Iron	BS EN 1563
4	Stem Nut	Gun Metal	BS 1400
5	Stem	Stainless Steel	BS EN 10088-3
6	Gasket	EPDM	BS EN 681
7	Bolts	Stainless Steel	BS EN 10088-3
8	Bonnet	Ductile Iron	BS EN 1563
9	O-Ring	EPDM	BS EN 681
10	Trust Collar	Gun Metal	BS 12165
11	O-Ring	EPDM	BS EN 681
12	O-Ring	EPDM	BS EN 681
13	Nylon Bush	Nylon	ASTM D4066
14	O-Ring	EPDM	BS EN 681
15	Mounting Flange	Ductile Iron	BS EN 1563

Specifications & Parameters Chart

DN (mm)	L (mm)	H (mm)	D (mm)
50	178	290	165
65	190	350	185
80	203	387	200
100	229	433	220
150	267	480	285
200	292	590	340
250	330	678	400
300	356	768	455
350	381	1118	520
400	406	1194	580
450	432	1297	640
500	457	1382	715
600	508	1580	840

Specifications & Parameters Chart

DN (mm)	L (mm)	D (mm)	ISO Flange
50	178	165	F10
65	190	185	F10
80	203	200	F10
100	229	220	F10
150	267	285	F10
200	292	340	F10/F14
250	330	400	F10/F14
300	356	455	F10/F14
350	381	520	On Request
400	406	580	
450	432	640	
500	457	715	
600	508	840	