

KEKALBOLEH SDN BHD

Company Registration No. 199901021248

Lot No. 7, Lorong Perindustrian Kolombong Jaya,
Pusat Perindustrian Kolombong Jaya,
Mile 5.5, Jalan Kolombong,
88450 Kota Kinabalu, Sabah, Malaysia.

☎ 088-385555

For more information
kekalboleh.com

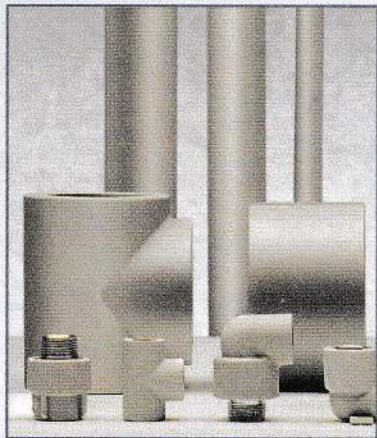
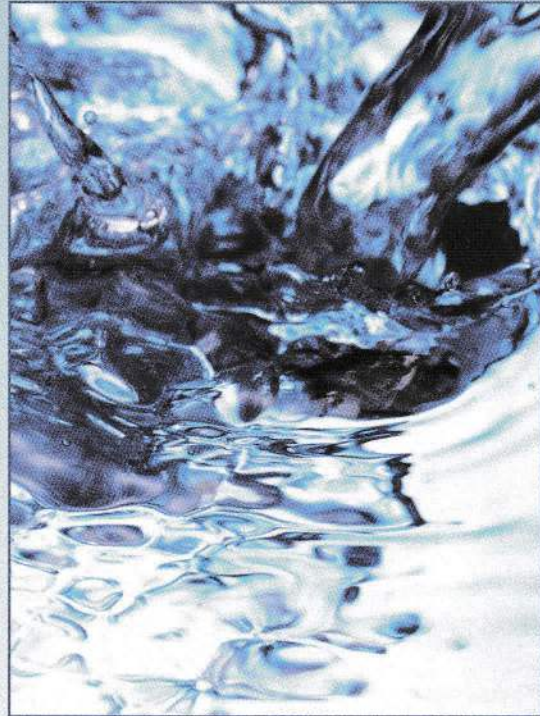
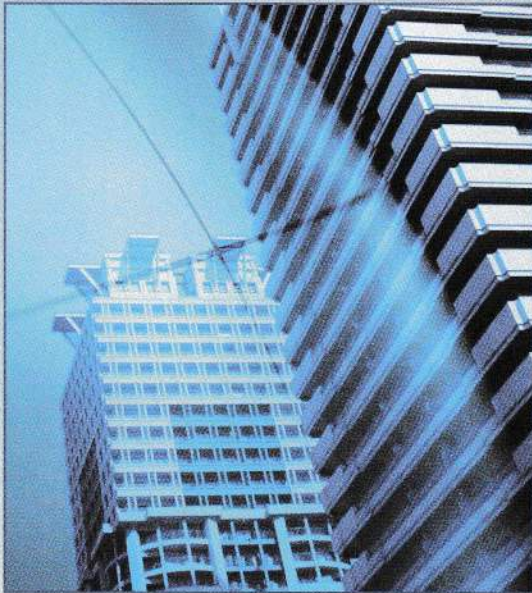

AQUASYSTEM

PP-R Piping System

+GF+

List of Abbreviations

d, d1, d2, D	Diameter
e	Wall thickness
g	Weight in gram
kg	Weight in kilogram
z	Pipe length between fittings
AL	Number of bolt holes
DIN	Deutsche Industrie-Normen
DN	Nominal diameter
EPDM	Ethylene Propylene Rubber
G	Pipe thread, not pressure tight in the thread to ISO 288-1
H, H1, H2	Height
ISO	International Standardization Organization
L, L1, L2	Length
PN	Nominal Pressure at 20°C, water
PP-R	Polypropylene Random
R	Taper male thread, pressure tight in the thread to ISO 7-1
RP	Parallel female thread, pressure tight in the thread to ISO 7-1
S	Pipe series
SDR	Standard Dimension Ratio
SP	Pieces per Standard Packaging
GP	Gross Packing

General Information

Dimension

All dimensions are given in mm and are intended as nominal or average sizes. Subject to alteration resulting from modifications in design.

Orders

Always quote the Georg Fischer code when placing orders.

Technical Information

For more detailed technical information, please consult our sales representative.

Ordering example

Pipe	d32	PP-R PN 10	300 206 004
Elbow 45°	d110	PP-R	300 206 060

Technical Standards

EN ISO 15874 : Plastics piping systems for hot and cold water installations - Polypropylene (PP)

EN ISO 15874 – Part 1: General (MS 2286-1)

EN ISO 15874 – Part 2: Pipes (MS 2286-2)

EN ISO 15874 – Part 3: Fittings (MS 2286-3)

EN ISO 15874 – Part 5: Fitness for purpose of the system (MS 2286-5)

EN ISO 15874 – Part 7: Guidance for the assessment of conformity

Other Reference Standards:

ISO 9080	Plastics piping and ducting systems – Determination of the long-term hydrostatic strength of thermoplastics materials in pipe form by extrapolation
ISO 9624	Thermoplastics pipes for fluids under pressure – Mating dimensions of flange adapters and loose backing flanges
ISO 10508	Plastics piping systems for hot and cold water installations – Guidance for classification and design
ISO 8795	Plastics piping systems for the transport of water intended for human consumption – Migration assessment
ISO/TR 10501	Thermoplastics pipes for the transport of liquids under pressure – Calculation of head losses
DIN 8077	Polypropylene (PP) Pipes – Dimensions
DIN 8078	Polypropylene (PP) Pipes – General quality requirements and testing
DIN 16962	Pipe Fittings & Joint Assemblies for Polypropylene (PP) Pressure Pipes
ENV 12108	Plastics piping systems – Recommended practice and techniques for the installation inside building structures of pressure piping systems for hot and cold water intended for human consumption
DVS 2207	Welding regulations for thermoplastic materials
MS 2286	Plastics piping systems for hot and cold water installations Polypropylene (PP)

TABLE OF CONTENTS

Introduction	2
+GF+ Piping Systems	
A Green Solutions	3
+GF+ AQUASYSTEM	16
+GF+ AQUASYSTEM	
Added Value	
Application Range	
Characteristics of the Material PP-R	
AQUASYSTEM Product Range	24
Pipes	
Socket Fusion Fittings	
Butt Fusion Fittings	
Electro Fusion Fittings	
Transition Fittings	
Valves	
Unions	
Machines & Tools	
General Precautions	57
Precautions	
Working with Plastic Pipes & Fittings	
Technical Features	60
Selection of Pipe Diameter	
Assessment of Pressure	
Regression Curve	
Permissible Operating Pressure	
PP-R Resin (Raw Material) Qualification	
Chemical Resistance	
Thermal Expansion & Contraction	
Position of the Flexible Arms	
Insulation & Thermal Conductivity	
Installation Recommendations	
Quality & Control	
Packaging	
Instruction for correct Installation	77
Electro Fusion Installation	
Socket Fusion Installation	
Butt Fusion Installation	
Hole Repairing	
Saddles Installation	
Approvals & Certificates	85



Unparalleled
hygiene standards
thanks to
modern plumbing
installations from
GF Piping Systems



+GF+ Piping Systems

Supplying the world with clean water is one of the major challenges of the 21st century. GF Piping Systems rises to this challenge by providing high quality piping systems. We develop and produce pipes, fittings, valves, flow measurement devices and fusion machines. These application-oriented system solutions allow transporting water, gas and industrial liquids safely and reliably. Whether in industry, utilities or building technology - GF Piping Systems has the right solution for you.

Innovation and technology

GF Piping Systems, through focussed research, is continually developing new products and technologies, setting new global standards in quality and performance for our customers.

All from one source

GF Piping Systems covers the growing demand for complete solutions from a single source in a wide range of applications.

Quality management

All system components are stringently tested in accredited test laboratories. Management and production procedures are certified to ISO 9001 and ISO 14001 to guarantee form, fit, function and compliance in whatever application they may be used throughout the world.

Sales and service – worldwide

Our local sales companies and representatives in over 100 countries provide "one stop" shopping, including planning support, training and product availability.

Facts and figures

GF Piping Systems with its 3 200 employees achieves an annual turnover of about CHF 1,299 million in 2012. GF Piping Systems is part of the Georg Fischer Corporation.

introduction

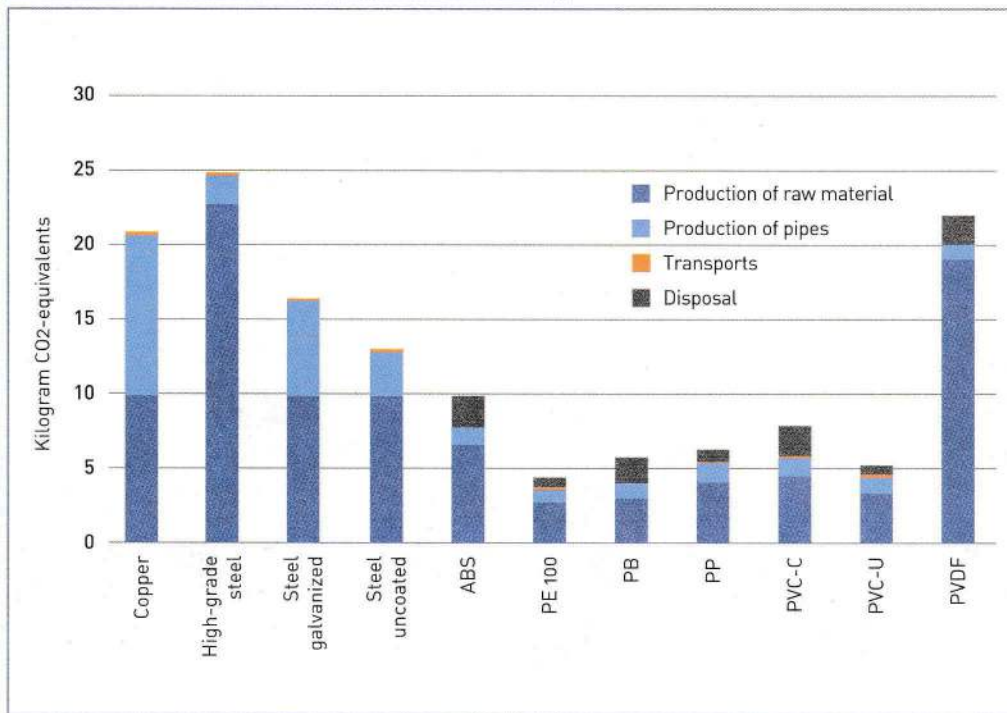

Pioneering Towards A Green Solutions

In focus: Plastics and metal

Climate change, the finiteness of fossil fuels and a rapidly rising demand for energy are among the challenges we face in the future.

For companies it will become even more important to offer products and solutions which match these challenges. For example, piping systems made of plastic cause less carbon dioxide emissions than metal piping systems. We offer complete plastic systems for nearly every application, whether in building technology, water treatment, cooling or other segments. Our plastic piping systems are leak proof, corrosion-resistant, lightweight and long-lived.

The added value of our solutions: plastics are "greener" than metals

Plastic piping systems of Georg Fischer offered applications and dimensions almost ever have better results than competitive materials. In the case of PP-R the carbon dioxide emissions are roughly five times lower than those of a comparable steel pipe. This is the result of a study that focused on the ecological footprint of various piping materials.

Our devotion

The environment and nature form the foundation of our lives. For that reason, Georg Fischer considers the consumption of energy and resources as well as the production of air emissions to be major challenges for an industry devoted to people.

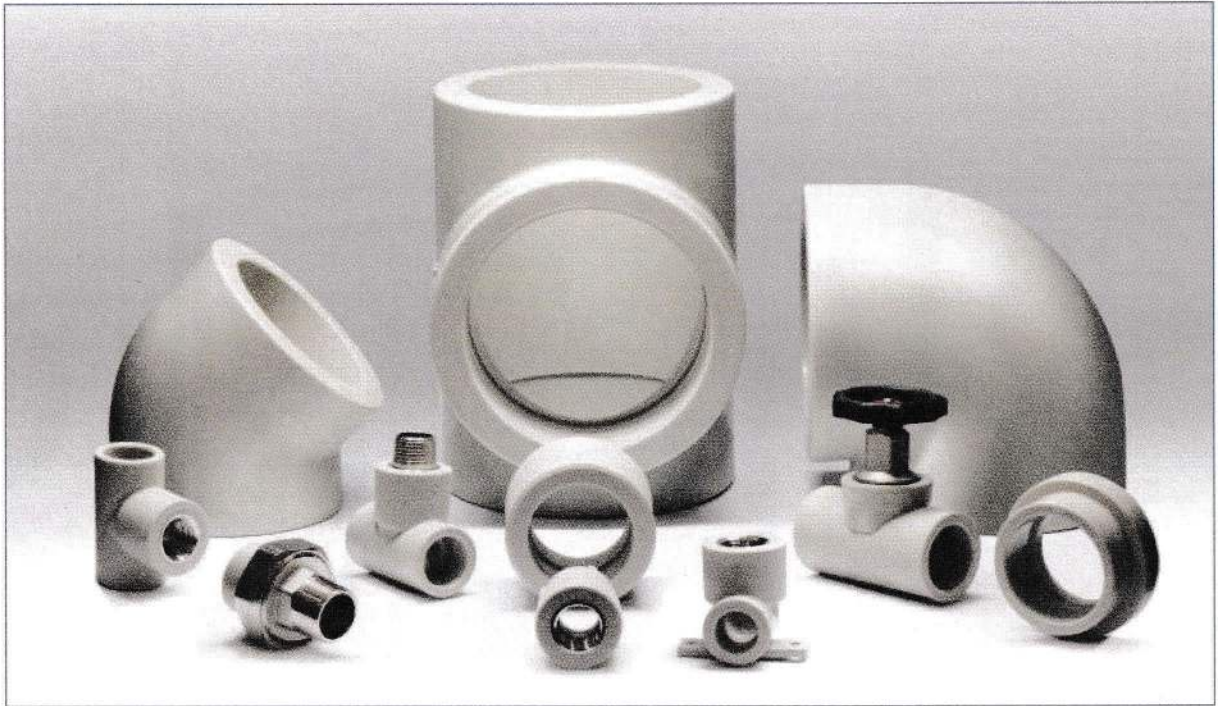

+GF+ AQUASYSTEM

AQUASYSTEM is a comprehensive plastic piping system which complies with the requirements for hot and cold plumbing system. The wide product range provides the right solution for each application: pipes for hot water (PN 20 & PN 16) and cold water (PN 16 & PN 10) as well as socket fusion fittings and a wide selection of metal transition fittings.

As a full system "AQUASYSTEM" is totally corrosion free, reduce noise transmission through pipes and save energy due to low thermal conductivity. The outstanding properties of PP-R and superior +GF+ product quality make AQUASYSTEM a practically maintenance free and extremely durable system. High quality plastic valves are also available.

Water services in buildings are complex, requiring both experience and careful material selection. The goal is to design and produce a piping system for hot and cold water supply that is easy to use and instal. All components are fully integrated and sturdy, whilst maintaining a competitive price.

Georg Fischer is a leader producer of pipe fittings made of various materials since 1858. In the field of thermoplastic materials, Georg Fischer is considered to be a pioneer, as well as one of the best known producers, utilising the most advanced technology in the world.

The test laboratory is one of the most established in the world in the field of plastic materials, and it is completely dedicated to research, development and testing of new products. The equipment and instruments used are the most modern and up-to-date in the market today, this makes it possible to carry out the most sophisticated tests.

This all comes together with the highest standard of technology, production and logistics, which contributes to guaranteeing the best product for the end users:

- quality
- experience
- reliability

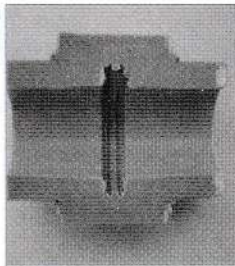

Homogeneous joint

AQUASYSTEM Added Value

- Longevity
Designed To Operate More Than 50 years
 - Low Density At 0.91g/cm³
(1/9 of Metal Pipes)
 - High Elasticity
 - » Resistance against impact and bending stresses
 - » Abrasion resistance
 - » Noise level reduced (water hammer)
 - Chemical Resistance:
 - » Hygienically safe
 - » No corrosion
 - Neutral Taste & Odour
 - » Suitable for food processing
 - Low Thermal Conductivity:
 - » Thermal losses reduced
 - » Low formation of condensation
 - Smooth Surfaces:
 - » Pressure losses reduced
 - » No incrustation
 - » Bacteriologically neutral
 - Low Electrical Conductivity
 - » No electrolytic corrosion
 - Fast & Easy installation
 - Leak Proof with homogenous Joints
- Benefits of Fusion Jointing:**
- Homogeneous connection
 - » No cement / glue used
 - » Fitting and pipe become one unit = Homogeneous
 - » Joint with same characteristics of pipe material
 - » No solvent that could affect the water quality
 - Easy and fast
 - » Socket Fusion jointing is done in seconds
 - » Only simple and inexpensive 230V tooling used
 - Reliable and long lasting
 - » No more leaking joints
 - » Life time of 50 Years or more
 - » Jointing system tested according to EN ISO 15874 - 5 & 7
 - No theft value



Hotel



Hospital



Industrial Building



Residential Building

Application Range

Hotel

Hotel guests expect first-class service which includes a perfectly functioning heating, air-conditioning and water supply at all times. Disturbances and noise – caused by repair work on defective piping systems – or even rust-coloured water from corroding pipes are unpleasant and make a negative impression on hotel guests. That is why it is always worth while to invest in good quality piping systems from GF Piping Systems. Our piping systems are corrosion – and repair-free and offer a prompt return on investment.

Hospital

Maintenance free Piping systems for water treatment, water supply and air-conditioning are of vital importance. Hygiene is another concern and everything must be in perfect working order. Quality products are therefore essential. Compact, space-saving fittings, flexible piping and easy installation technology are the answer. GF Piping Systems supplies all this and more. You, your engineers and installers are provided with solutions for all your needs.

Industrial Building

Factories, production plants or research facilities – the requirements are extremely diverse. But they have one thing in common: they all need a reliable supply of water, gas and compressed air. Production processes must operate without fail. Whether a new building, renovation or extension – GF Piping Systems has optimal systems for all areas so that you are assured the best possible solution. We focus on such important features as safety, environment protection, durability and cost effectiveness.

Residential Building

Home owners expect leak free and reliable piping systems for plumbing heating and air conditioning installations. Piping systems that are embedded in walls and floors must be of highest quality to ensure trouble-free use over years. Our long proven systems provide clean water in houses and apartments, no more rust coloured water due to corroding pipes. All our products are hygienic and safe. No toxic chemicals are used for manufacturing or jointing of pipes and fittings. Our systems are affordable but very durable and conform with international standards.

Hot and Water 1

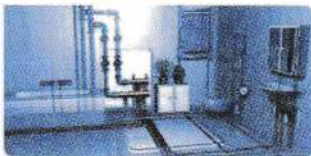

Chilled Water 2



Compressed Air 3



Heating 4



Characteristics of the material PP-R

Pipes and fittings are made of Polypropylene Random, also known as type 3. The quality of our material can guarantee a long life (50 years), high resistance to pressure and temperature. This material is suitable for hot and cold water and heating systems.

The special properties of the material, compared to the other materials, give the following advantages

- high dimensional stability (when hot)
- maximum resilience

Properties	ISO	DIN	Unit	Values
Flow index	ISO 1133	DIN 53735		
MFI 190/5	Procedure 18f	Code T	g/10 min	0,4
MFI 230/2,16	Procedure 12	Code M	g/10 min	0,25
MFI 230/5	Procedure 20	Code V	g/10 min	1,25
Density a 23°C	ISO/R 1183	DIN 53479	g/cm ³	0,90-0,91
Resilience (Charpy)				
23°C	ISO 179/2D	DIN 53479	kJ/m ²	n.r.
-30°C	ISO 179/2D	normal scale	kJ/m ²	40
Chipping resilience (notch-engraved sample test)				
23°C	ISO 179/2C	DIN 53453	kJ/m ²	25
-30°C	ISO 179/2C	normal scale	kJ/m ²	2,5
Resilience (Izod)				
23°C	ISO 180/1C	-	kJ/m ²	n.r.
-30°C	ISO 180/1C	-	kJ/m ²	28
Scratching resilience (engraved sample test) (Izod)				
23°C	ISO 180/1A	-	kJ/m ²	23
-30°C	ISO 180/1A	-	kJ/m ²	2,5
23°C	ASTM D 256	-	kJ/m ²	27
-30°C	ASTM D 256	-	kJ/m ²	4
Traction test				
Yield test	ISO 527	DIN 53455	N/mm ²	27
Yield Elasticity	Forwarding speed	Forwarding speed	%	11
Breakage Elongation	-	-	%	> 800
Traction Module E	ISO 527	DIN 53457	N/mm ²	900
Elasticity yield to tangential tension	ISO/R 537Metod A.	DIN 53445	N/mm ²	450
Bending stress 3,5%	ISO 178 standard test 5.1	DIN 53452	N/mm ²	24
Brinell hardness test	ISO 2039 (H358/30)	DIN 53456 (H358/30)	N/mm ²	49
VICAT A/°C Melting point	ISO 306	DIN 53460	°C	135-145
Dimensional heat stability °C	ISO 75/B	DIN 53461	°C	75
Surface Resistance		DIN 53482	Ω	>10 ¹³
Mass resistivity		DIN 53482	Ω cm	>10 ¹⁶
Dielectric loss angle (tg.) (106Hz)		DIN 53483	-	2 x 10 ⁻⁴
Relative dielectric constant (10-6Hz)		DIN 53483	-	2,3
Dielectric rigidity		ASTM D149	kV/mm	75
Termal conductivity at 20° C	VDE 0304 (1-4)	52612	W/mK	0,22
Termal expansion factor			mm/m°C	0,15
Specific heat 20°C			Kj/KgK	2,0

The characteristics are the results of the tests on extruded samples after 96 hours storage at normal room conditions 23/50 (2) DIN 50014 and represent indicative values.

Resistance to internal hydrostatic pressure

Condition		Required	Typical Value	Test Method
20°C	16 MPa	1 hr	→10 hrs	ISO 1167
95°C	3.5 MPa	1,000 hrs	→5,000 hrs	ISO 1167
110°C	1.9 MPa	8,760 hrs	→10,000 hrs	ISO 1167

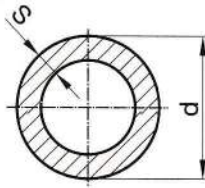
+GF+ AQUASYSTEM – Pipe PN 10**1001**

- Polypropylene-Random (PP-R)
- EN ISO 15874, DIN 8077, DIN 8078, MS 2286
- PN 10, SDR II, ISO Series 5
- Colour: Grey

d x s (mm)	Code	Code	SP (m)	Kg/m	Length (m)
	Blue Strips	Lilac Strips*			
20 x 1.9	300 206 012		100	0.107	4
25 x 2.3	300 206 013	300 206 213	60	0.164	4
32 x 2.9	300 206 014	300 206 214	48	0.261	4
40 x 3.7	300 206 015	300 206 215	32	0.412	4
50 x 4.6	300 206 016	300 206 216	20	0.638	4
63 x 5.8	300 206 017	300 206 217	16	1.010	4
75 x 6.8	300 206 018	300 206 218	12	1.410	4
90 x 8.2	300 206 019	300 206 219	8	2.030	4
110 x 10.0	300 206 020	300 206 220	4	3.010	4
125 x 11.4	300 206 021	300 206 221	4	3.910	4
160 x 14.6	300 206 945		4	6.380	4

* For Grey Water Application

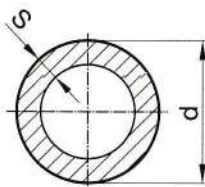
+GF+ AQUASYSTEM – Pipe PN 16**1002**

- Polypropylene-Random (PP-R)
- EN ISO 15874, DIN 8077, DIN 8078, MS 2286
- PN 16, SDR 7.4, ISO Series 3.2
- Colour: Grey

d x s (mm)	Code	Code	SP (m)	Kg/m	Length (m)
	Blue Strips	Red Strips			
20 x 2.8	300 206 932	300 206 950	100	0.148	4
25 x 3.5	300 206 933	300 206 951	60	0.230	4
32 x 4.4	300 206 934	300 206 952	48	0.370	4
40 x 5.5	300 206 935	300 206 953	32	0.575	4
50 x 6.9	300 206 936	300 206 954	20	0.896	4
63 x 8.6	300 206 937	300 206 955	16	1.410	4
75 x 10.3	300 206 938	300 206 956	12	2.010	4
90 x 12.3	300 206 939	300 206 957	8	2.870	4
110 x 15.1	300 206 940	300 206 958	4	4.300	4
125 x 17.1	300 206 941	300 206 959	4	5.530	4
160 x 21.9	300 206 942	300 206 960	4	9.040	4

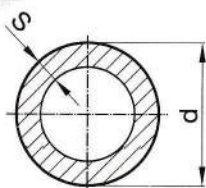
+GF+ AQUASYSTEM – Pipe PN 20**1003**

- Polypropylene-Random (PP-R)
- EN ISO 15874, DIN 8077, DIN 8078, MS 2286
- PN 20, SDR 6, ISO Series 2.5
- Colour: Grey

d x s (mm)	Code	Code	SP (m)	Kg/m	Length (m)
	Red Strips	Blue Strip			
20 x 3.4	300 206 002	300 206 970	100	0.172	4
25 x 4.2	300 206 003	300 206 971	60	0.266	4
32 x 5.4	300 206 004	300 206 972	48	0.434	4
40 x 6.7	300 206 005	300 206 973	32	0.671	4
50 x 8.3	300 206 006	300 206 974	20	1.040	4
63 x 10.5	300 206 007	300 206 975	16	1.650	4
75 x 12.5	300 206 008	300 206 976	12	2.340	4
90 x 15.0	300 206 009	300 206 977	8	3.360	4
110 x 18.3	300 206 010	300 206 978	4	5.010	4

Socket

2001

- +GF+ AQUASYSTEM
- EN ISO 15874, DIN 16962, MS 2286
- Polypropylene-Random (PP-R)
- Colour: Grey

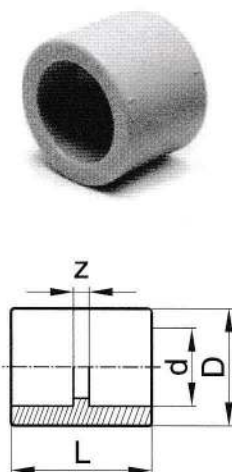

d (mm)	Code	GP	g	D (mm)	L (mm)	z (mm)
20	300 206 022	300	12	29	34	2
25	300 206 023	200	16	34	38	2
32	300 206 024	160	27	43	43	3
40	300 206 025	200	50	55	47	3
50	300 206 026	120	92	70	53	3
63	300 206 027	60	177	88	62	4
75	300 206 028	25	242	103	67	5
90	300 206 029	16	347	122	73	5
110	300 206 030	10	586	148	83	5
125	300 206 031	8	699	160	91	5

Elbow 90°

2002

- +GF+ AQUASYSTEM
- EN ISO 15874, DIN 16962, MS 2286
- Polypropylene-Random (PP-R)
- Colour: Grey

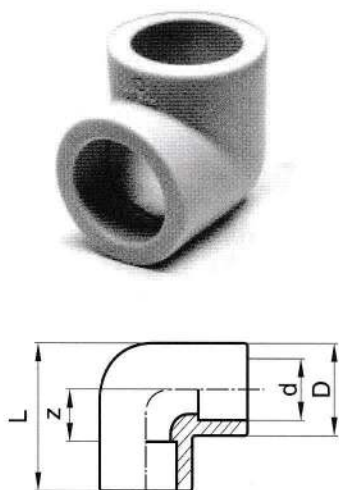

d (mm)	Code	GP	g	D (mm)	L (mm)	z (mm)	
20	300 206 032	250	18	29	42	5	
25	300 206 033	150	30	34	48	6	
32	300 206 034	200	46	43	60	10	
40	300 206 035	120	90	55	71	14	
50	300 206 036	60	188	70	88	19	
63	300 206 037	30	343	88	106	24	
75	300 206 038	10	490	103	124	31	
90	300 206 039	6	775	122	145	39	
110	300 206 040	8	1260	148	171	47	
125	300 206 041	1	2311	160	195	55	
160	300 206 601	Please refer to Butt Fusion Section					

Elbow 45°

2003

- +GF+ AQUASYSTEM
- EN ISO 15874, DIN 16962, MS 2286
- Polypropylene-Random (PP-R)
- Colour: Grey

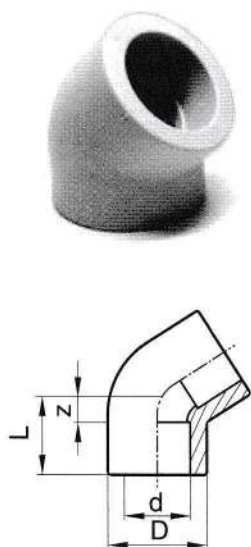

d (mm)	Code	GP	g	D (mm)	L (mm)	z (mm)	
20	300 206 052	300	15	29	21	5	
25	300 206 053	200	20	34	24	6	
32	300 206 054	300	31	43	27	7	
40	300 206 055	150	69	55	31	9	
50	300 206 056	80	124	70	37	12	
63	300 206 057	40	237	88	45	16	
75	300 206 058	10	365	103	121	20	
90	300 206 059	6	592	122	142	22	
110	300 206 060	8	952	148	164	33	
125	300 206 061	1	1080	160	185	52	
160	300 206 611	Please refer to Butt Fusion Section					

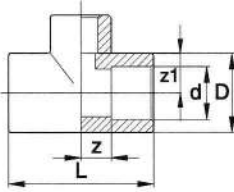

Equal Tee 90°

2004

- +GF+ AQUASYSTEM
- Polypropylene-Random (PP-R)
- EN ISO 15874, DIN 16962, MS 2286
- Colour: Grey

d (mm)	Code	GP	g	D (mm)	L (mm)	z (mm)	z1 (mm)	
20	300 206 062	200	23	29	55	12	10	
25	300 206 063	300	36	34	64	14	14	
32	300 206 064	160	69	43	77	19	19	
40	300 206 065	80	126	55	87	22	23	
50	300 206 066	50	229	70	105	28	28	
63	300 206 067	25	444	88	126	34	35	
75	300 206 068	20	584	103	141	40	42	
90	300 206 069	10	932	122	163	48	46	
110	300 206 070	6	1077	145	197	60	59	
125	300 206 100	1	1685	160	216	65	64	
160	300 206 621	Please refer to Butt Fusion Section						

Reducing Tee 90°

2005

- +GF+ AQUASYSTEM
- Polypropylene-Random (PP-R)
- EN ISO 15874, DIN 16962, MS 2286
- Colour: Grey

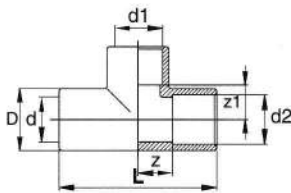

d-d1-d2 (mm)	Code	GP	g	D (mm)	L (mm)	z (mm)	z1 (mm)
25-20-25	300 206 071	250	38	34	64	14	16
32-20-32	300 206 074	160	64	43	77	19	22
32-25-32	300 206 075	60	65	43	77	19	20
40-20-40	300 206 078	100	113	55	88	22	28
40-25-40	300 206 079	100	114	55	88	22	26
40-32-40	300 206 080	80	115	55	88	22	24
50-20-50	300 206 081	60	208	70	106	28	36
50-25-50	300 206 082	60	210	70	106	28	34
50-32-50	300 206 083	60	215	70	106	28	32
50-40-50	300 206 084	50	218	70	106	28	30
63-25-63	300 206 085	25	397	88	128	35	45
63-32-63	300 206 086	10	399	88	128	35	43
63-40-63	300 206 087	25	403	88	128	35	41
63-50-63	300 206 088	25	414	88	128	35	38
75-25-75	300 206 097	20	532	103	141	40	51
75-32-75	300 206 089	20	533	103	141	40	49
75-40-75	300 206 090	20	537	103	141	40	47
75-50-75	300 206 091	20	548	103	141	40	44
75-63-75	300 206 092	20	564	103	141	40	40
90-32-90	300 206 093	10	866	122	163	48	57
90-40-90	300 206 094	10	871	122	163	48	55
90-50-90	300 206 095	10	878	122	163	48	52
90-63-90	300 206 096	10	889	122	163	48	48
110-50-110	300 206 098	6	1490	148	197	60	61
110-63-110	300 206 099	6	1490	148	197	60	57

Reducing Bush

- +GF+ AQUASYSTEM
- EN ISO 15874, DIN 16962, MS 2286
- Polypropylene-Random (PP-R)
- Colour: Grey

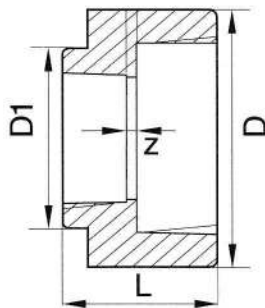
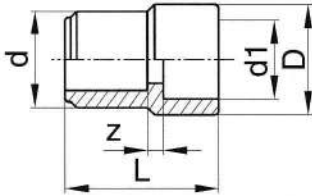

d-d1 (mm)	Code	GP	g	D (mm)	L (mm)	z (mm)	D1 (mm)
25-20	300 206 102	400	10	29	38	4	
32-20	300 206 103	240	16	29	39	5	
32-25	300 206 104	200	18	34	43	4	
40-20	300 206 105	150	23	29	44	5	
40-25	300 206 106	150	24	34	44	5	
40-32	300 206 107	250	34	43	50	7	
50-20	300 206 108	100	41	29	50	5	
50-25	300 206 109	100	40	34	50	6	
50-32	300 206 110	40	44	43	50	4	
50-40	300 206 111	40	61	55	57	5	
63-20	300 206 112	60	73	29	63	9	
63-25	300 206 113	80	74	34	63	10	
63-32	300 206 114	50	73	43	59	8	
63-40	300 206 115	50	74	55	55	4	
63-50	300 206 116	40	111	70	64	6	
75-25	300 206 118	25	251	103	54	5	34
75-32	300 206 119	25	255	103	56	5	44
75-40	300 206 120	25	247	103	58	5	55
75-50	300 206 121	25	245	103	61	5	70
75-63	300 206 122	25	252	103	65	5	88
90-50	300 206 125	10	357	122	64	5	70
90-63	300 206 126	16	357	112	68	5	88
90-75	300 206 127	16	361	112	70	5	103
110-63	300 206 129	10	604	148	74	6	88
110-75	300 206 130	10	589	148	75	5	103
110-90	300 206 131	10	585	148	78	5	122
125-110	300 206 132	10	920	160	90	8	148

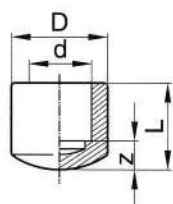

End Cap

2007

- +GF+ AQUASYSTEM
- EN ISO 15874, DIN 16962, MS 2286
- Polypropylene-Random [PP-R]
- Colour: Grey

d-1 (mm)	Code	GP	g	D (mm)	L (mm)	z (mm)	
20	300 203 132	300	7	28	22	9	
25	300 203 133	200	9	35	25	7	
32	300 203 134	200	15	114	30	9	
40	430 190 400 6321	150	31	53	31	11	
50	430 190 500 6421	80	69	67	41	7	
63	430 190 630 6522	50	115	83	44	17	

Swan Neck

2008

- +GF+ AQUASYSTEM
- EN ISO 15874, DIN 16962, MS 2286
- Polypropylene-Random [PP-R]
- Colour: Grey

d (mm)	Code	GP	g	L (mm)	L1 (mm)	
20	300 203 142	80	44	300	40	
25	300 203 143	50	75	320	60	
32	300 203 144	30	126	350	64	

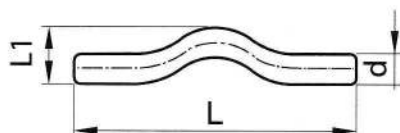
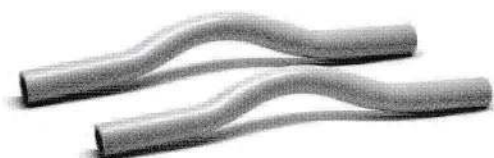

Manifold

2009

- +GF+ AQUASYSTEM
- EN ISO 15874, DIN 16962, MS 2286
- Polypropylene-Random [PP-R]
- Colour: Beige

d (mm)	Code	SP	GP	g	D (mm)	L (mm)	z (mm)	
40 X 20	760 840 182	1	10	203	55	255	57	
40 X 1/2"	760 840 186	1	10	461	55	255	57	

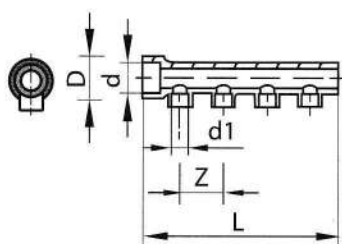
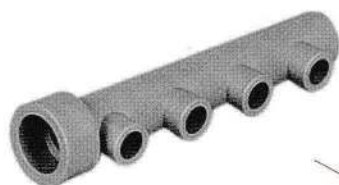

Saddle with Spigot

2010

- +GF+ AQUASYSTEM
- EN ISO 15874, DIN 16962, MS 2286
- Polypropylene-Random (PP-R)
- Colour: Beige

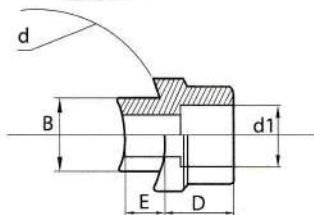

d-d1 (mm)	Code	SP	GP	B (mm)	D (mm)	E (mm)	
40-20	760 840 190	10	10	22	20	6,5	
40-25	760 840 191	10	10	22	27	6,5	
50-20	760 840 192	10	10	22	20	8	
50-25	760 840 193	10	10	22	27	8	
63-20	760 840 194	10	10	22	20	10	
63-25	760 840 195	10	10	22	27	10	
63-32	760 840 196	10	10	32	30	10	
75-20	760 840 197	10	10	22	20	10	
75-25	760 840 198	10	10	22	27	10	
75-32	760 840 199	10	10	32	30	10	
75-40	760 840 200	10	10	32	30	15	
90-20	760 840 220	10	10	22	20	15	
90-25	760 840 221	10	10	22	27	15	
90-32	760 840 222	10	10	32	30	15	
90-40	760 840 231	10	10	32	30	15	
110-20	760 840 223	10	10	22	20	15	
110-25	760 840 224	10	10	22	27	15	
110-32	760 840 225	10	10	32	30	15	
110-40	760 840 226	10	10	32	30	15	
125-20	760 840 227	10	10	22	27	15	
125-25	760 840 228	10	10	22	30	15	
125-32	760 840 229	10	10	32	30	15	
125-40	760 840 230	10	10	32	30	15	

Threaded Female Saddles with Spigot

2011

- +GF+ AQUASYSTEM
- EN ISO 15874, DIN 16962, MS 2286
- Polypropylene-Random (PP-R)
- Colour: Beige

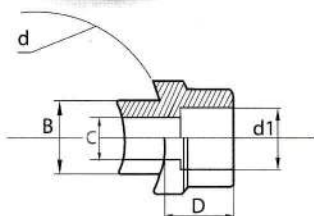

d-Rp (mm)/(inch)	Code	SP	GP	B (mm)	C (mm)	D (mm)	
40-1/2	760 840 764	10	10	22	13	27	
50-1/2	760 840 766	10	10	22	13	27	
50-3/4	760 840 767	10	10	32	21	30	
63-1/2	760 840 768	10	10	22	13	27	
63-3/4	760 840 769	10	10	32	21	30	
75-1/2	760 840 770	10	10	22	13	27	
75-3/4	760 840 771	10	10	32	21	30	
75-1	760 840 772	10	10	32	22	34	
90-1/2	760 840 773	10	10	22	13	27	
90-3/4	760 840 774	10	10	32	21	30	
90-1	760 840 775	10	10	32	22	34	
110-1/2	760 840 776	10	10	22	13	27	
110-3/4	760 840 777	10	10	32	21	30	
110-1	760 840 778	10	10	32	22	34	
125-1/2	760 840 779	10	10	22	14	27	
125-3/4	760 840 780	10	10	32	22	30	
125-1	760 840 781	10	10	32	22	34	

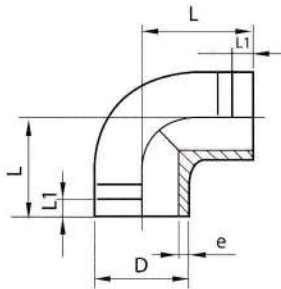

Elbow 90° **

3002

- +GF+ AQUASYSTEM
- Polypropylene-Random (PP-R)

• Colour: Grey

PN 16

d (mm)	Code	GP	Kg	L (mm)	L1 (mm)	e (mm)		
160	300 206 601	1	4.470	231	99	21.9		

PN 10 • Chamfered from PN 16

d (mm)	Code	GP	Kg	L (mm)	L1 (mm)	e (mm)		
160	300 206 605	1	4.270	231	99	14.6		

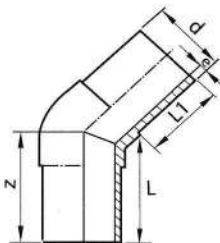

Elbow 45° **

3003

- +GF+ AQUASYSTEM
- Polypropylene-Random (PP-R)

• Colour: Grey

PN 16

d (mm)	Code	GP	Kg	L (mm)	L1 (mm)	e (mm)		
160	300 206 611	1	3.740	151	99	21.9		

PN 10 • Chamfered from PN 16

d (mm)	Code	GP	Kg	L (mm)	L1 (mm)	e (mm)		
160	300 206 615	1	3.540	151	99	14.6		

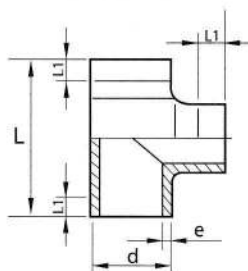
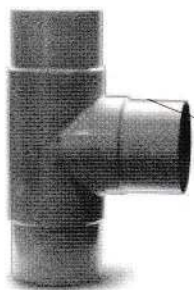

Equal Tee 90° **

3004

- +GF+ AQUASYSTEM
- Polypropylene-Random (PP-R)

• Colour: Grey

PN 16

d (mm)	Code	GP	Kg	L (mm)	L1 (mm)	e (mm)		
160	300 206 621	1	6.180	475	99	21.9		

PN 10 • Chamfered from PN 16

d (mm)	Code	GP	Kg	L (mm)	L1 (mm)	e (mm)		
160	300 206 625	1		475	99	14.6		



(actual product differ from picture)

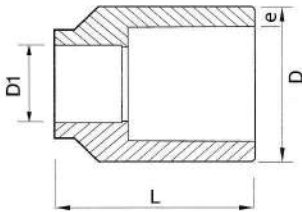

Reducer **

3007

- +GF+ AQUASYSTEM
- Polypropylene-Random (PP-R)
- Colour: Grey
- Below 160mm fittings ends are only suited for socket fusion welding
- Fabricated fittings

PN 16

d (mm)	Code	GP	Kg	L (mm)	e (mm)	d	d1
160-110	300 206 138	1	1.31	164	21.9	160	110

PN 10 • Chamfered from PN 16

d (mm)	Code	GP	Kg	L (mm)	e (mm)	d	d1
160-110	300 206 139	1	1.2	164	14.6	160	110

Reducer **

3007

- +GF+ AQUASYSTEM
- Polypropylene-Random (PP-R)
- Colour: Grey
- Below 160mm fittings ends are only suited for socket fusion welding
- Fabricated fittings

PN 16

d (mm)	Code	GP	Kg	L (mm)	e (mm)	d	d1
160-125	300 206 642	1	2.30	255	21.9	160	125

PN 10 • Chamfered from PN 16

d (mm)	Code	GP	Kg	L (mm)	e (mm)	d	d1
160-125	300 206 662	1	2.15	255	14.6	160	125

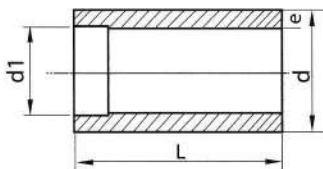

Reducing Tee 90° **

- +GF+ AQUASYSTEM
- Polypropylene-Random (PP-R)
- Colour: Grey

PN 16

d-d1 (mm)	Code	GP	Kg	L (mm)	L1 (mm)	e (mm)
160-63	300 206 151	1	6.77	475	312	21.9
160-75	300 206 152	1	6.786	475	324	21.9
160-90	300 206 153	1	6.801	475	327	21.9

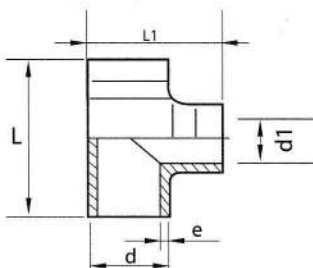

** Buttfusion data from Machine Manual.

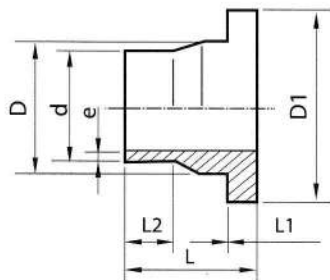

Flange Adaptor **

3012

- +GF+ AQUASYSTEM
- Polypropylene-Random (PP-R)

• Colour: Grey

PN 16

d (mm)	Code	GP	Kg	L (mm)	L1 (mm)	L2 (mm)	D (mm)	D1 (mm)	e (mm)
160	300 206 651	6	1.740	158	25	99	175	212	21.9

PN 10 • Chamfered from PN 16

d (mm)	Code	GP	Kg	L (mm)	L1 (mm)	L2 (mm)	D (mm)	D1 (mm)	e (mm)
160	300 206 657	6	1.540	158	25	99	175	212	14.6

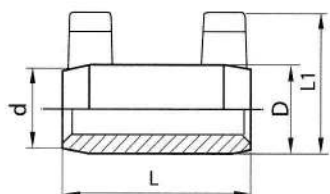

Electric Socket **

4001

- +GF+ AQUASYSTEM
- Polypropylene-Random (PP-R)

• Colour: Beige

d (mm)	Code	SP	GP	g (mm)	D (mm)	L (mm)	L1 (mm)
20	760 840 452	10	10	40	33	70	50
25	760 840 453	10	10	49	38	70	57
32	760 840 454	10	10	63	46	79	62
40	760 840 455	5	5	92	55	90	71
50	760 840 456	2	2	149	67	100	82
63	760 840 457	1	1	263	86	106	101
75	760 840 458	1	1	320	103	121	115
90	760 840 459	1	1	475	121	131	134
110	760 840 460	1	1	805	142	142	156
125	760 840 461	1	1	1080	163	151	175
160	760 840 470	1	1	1950	183	161	195

Threaded Male Coupling

5001

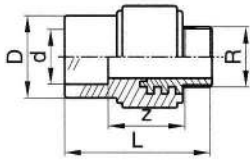

- +GF+ AQUASYSTEM
- EN ISO 15874, DIN 16962, MS 2286
- Polypropylene-Random (PP-R)
- Colour: Grey
- Brass Male - Threaded
- Nickel Coating

d-R (mm) (inch)	Code	Code* (DZR Brass)	GP	g (mm)	D (mm)	L (mm)	z (mm)
20-1/2	300 206 241	300 206 841	80	75	28	56	25
20-3/4	300 206 242	300 206 842	60	98	34	59	24
25-1/2	300 206 243	300 206 843	60	75	33	58	25
25-3/4	300 206 244	300 206 844	60	96	34	59	24
32-3/4	300 206 245	300 206 845	60	99	42	61	23
32-1	300 206 246	300 206 846	30	204	43	75	22
40-1 1/4	300 206 248	300 206 848	10	402	54	90	31
50-1 1/2	300 206 249	300 206 849	10	526	68	93	31
63-2	300 206 250	300 206 850	6	719	86	105	30

Threaded Female Coupling

5002

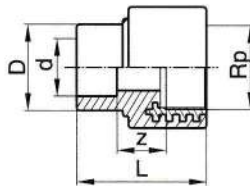

- +GF+ AQUASYSTEM
- EN ISO 15874, DIN 16962, MS 2286
- Polypropylene-Random (PP-R)
- Colour: Grey
- Brass Female - Threaded
- Nickel Coating

d-Rp (mm) (inch)	Code	Code* (DZR Brass)	GP	g (mm)	D (mm)	L (mm)	z (mm)
20-1/2	300 206 271	300 206 861	80	50	28	41	25
20-3/4	300 206 272	300 206 862	80	67	34	42	26
25-1/2	300 206 273	300 206 863	80	52	33	43	25
25-3/4	300 206 274	300 206 864	60	65	34	42	24
32-3/4	300 206 275	300 206 865	60	69	42	44	22
32-1	300 206 276	300 206 866	30	130	43	56	23
40-1 1/4	300 206 278	300 206 868	10	274	54	69	31
50-1 1/2	300 206 279	300 206 869	10	384	68	72	31
63-2	300 206 280	300 206 870	6	492	86	80	31

* Brass insert in dezincification resistant material (DZR)

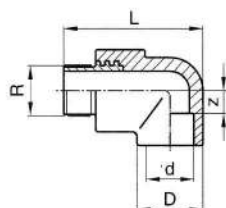

Threaded Male Elbow 90°

5003

- +GF+ AQUASYSTEM
- EN ISO 15874, DIN 16962, MS 2286
- Polypropylene-Random (PP-R)
- Colour: Grey
- Brass Male - Threaded
- Nickel Coating

d-Rp (mm) (inch)	Code	Code* (DZR Brass)	GP	g (mm)	D (mm)	L (mm)	z (mm)
20-1/2	300 206 291	300 206 881	50	81	30	65	12
20-3/4	300 206 292	300 206 882	50	102	30	66	12
25-1/2	300 206 293	300 206 883	40	94	34	72	14
25-3/4	300 206 294	300 206 884	40	113	34	74	14
32-3/4	300 206 295	300 206 885	25	128	42	82	16
32-1	300 206 296	300 206 886	20	165	44	95	19

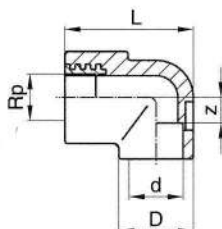
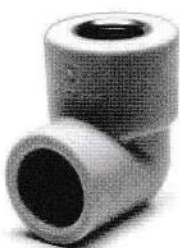

Threaded Female Elbow 90°

5004

- +GF+ AQUASYSTEM
- EN ISO 15874, DIN 16962, MS 2286
- Polypropylene-Random (PP-R)
- Colour: Grey
- Brass Female - Threaded
- Nickel Coating

d-Rp (mm) (inch)	Code	Code* (DZR Brass)	GP	g (mm)	D (mm)	L (mm)	z (mm)
20-1/2	300 206 301	300 206 891	50	59	30	50	12
20-3/4	300 206 302	300 206 892	50	72	30	50	12
25-1/2	300 206 303	300 206 893	50	70	34	57	14
25-3/4	300 206 304	300 206 894	40	93	34	57	14
32-3/4	300 206 305	300 206 895	30	96	42	65	16
32-1	300 206 306	300 206 896	20	163	44	77	19

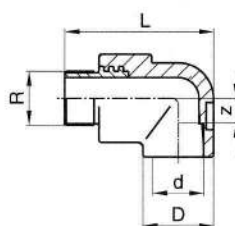

Threaded Male Elbow 90° with Bracket

5005

- +GF+ AQUASYSTEM
- EN ISO 15874, DIN 16962, MS 2286
- Polypropylene-Random (PP-R)
- Colour: Grey
- Brass Male - Threaded
- Nickel Coating

d-R (mm) (inch)	Code	Code* (DZR Brass)	GP	g (mm)	D (mm)	L (mm)	z (mm)
20-1/2	300 206 321	300 206 901	50	83	30	65	12

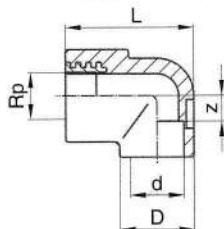

Threaded Female Elbow 90° with Bracket

5006

- +GF+ AQUASYSTEM
- EN ISO 15874, DIN 16962, MS 2286
- Polypropylene-Random (PP-R)
- Colour: Grey
- Brass Female - Threaded
- Nickel Coating

d-Rp (mm) (inch)	Code	Code* (DZR Brass)	GP	g (mm)	D (mm)	L (mm)	z (mm)
20-1/2	300 206 331	300 206 905	50	61	30	50	12

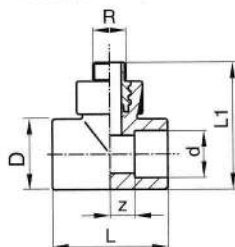

Threaded Male Tee

5007

- +GF+ AQUASYSTEM
- EN ISO 15874, DIN 16962, MS 2286
- Polypropylene-Random (PP-R)
- Colour: Grey
- Brass Male - Threaded
- Nickel Coating

d-R (mm) (inch)	Code	Code* (DZR Brass)	GP	g (mm)	D (mm)	L (mm)	L1 (mm)	z (mm)
20-1/2	300 206 341	300 206 911	50	85	29	55	65	12
25-1/2	300 206 343	300 206 913	50	97	34	64	72	14
25-3/4	300 206 344	300 206 914	40	119	34	64	74	14
32-3/4	300 206 345	300 206 915	30	145	44	77	81	19
32-1	300 206 346	300 206 916	20	247	43	77	96	19

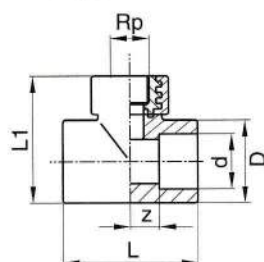

Threaded Female Tee

5008

- +GF+ AQUASYSTEM
- EN ISO 15874, DIN 16962, MS 2286
- Polypropylene-Random (PP-R)
- Colour: Grey
- Brass Female - Threaded
- Nickel Coating

d-R (mm) (inch)	Code	Code* (DZR Brass)	GP	g (mm)	D (mm)	L (mm)	L1 (mm)	z (mm)
20-1/2	300 206 351	300 206 921	50	62	29	55	50	12
25-1/2	300 206 353	300 206 923	50	74	34	64	57	14
25-3/4	300 206 354	300 206 924	40	86	34	64	57	14
32-3/4	300 206 356	300 206 926	30	114	44	77	64	19
32-1	300 206 357	300 206 927	20	174	43	77	78	19

* Brass insert in dezincification resistant material (DZR)

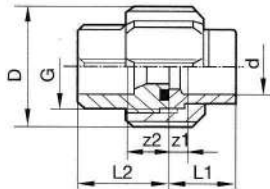

Union Socket PP-H (PN 10)

5009

- Polypropylene Homo Polymeride [PP-H]
- High Impact Strength, abrasion and chemicals

d (mm)	Code	GP	g	D (mm)	L1 (mm)	L2 (mm)	z1 (mm)	z2 (mm)	G (inch)
25	727 510 157	1	62	58	21	28	5	12	1¼
32	727 510 158	1	79	65	23	30	5	12	1½
40	727 510 159	1	137	79	25	34	5	14	2
50	727 510 160	1	180	91	28	39	5	16	2¼
63	727 510 161	1	312	111	32	47	5	20	2¾

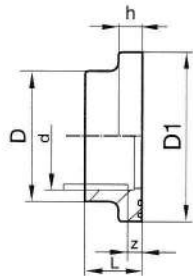

Flange Adaptor

2012

- +GF+ AQUASYSTEM
- Polypropylene-Random (PP-R)
- EN ISO 15874, DIN 16962, MS 2286
- Colour: Grey
- Socket - Fusion

d (mm)	Code	GP	g	D (mm)	L (mm)	D1 (mm)	z (mm)	h (mm)
40	300 206 415	200	30	50	28	62	6	10
50	300 206 416	120	45	61	31	74	6	12
63	300 206 417	60	74	76	35	91	6	14
75	300 206 418	25	110	90	37	108	6	13
90	300 206 419	16	163	108	40	128	6	16
110	300 206 420	10	242	131	45	151	6	19
125	300 206 421	8	337	148	53	169	10	20
160	300 206 651	Please refer to Butt Fusion Section						

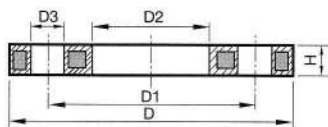
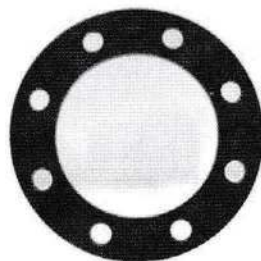

Backing Flange

5010

- +GF+ AQUASYSTEM
- Coated with PP
- Galvanized Steel

d (mm)	Code	SP	D	D1 (mm)	D2 (mm)	D3 (mm)	H (mm)	AL
40	727 700 209C	1	140	100	54	18	18	4
50	727 700 210C	1	150	110	67	18	20	4
63	727 700 211C	1	165	125	85	18	20	4
75	727 700 212C	1	185	145	100	18	20	8
90	727 700 213C	1	200	160	120	18	22	8
110	727 700 214C	1	220	180	147	18	22	8
125	727 700 215	1	250	210	150	18	22	8
160*	727 700 317	1	285	240	178	22	24	8

Flat Gasket EPDM

- +GF+ AQUASYSTEM
- EPDM Material
- Intergrated Fixation
- Suited for all metric +GF+ Flange Adaptors
- Hardness approx. 65° shore

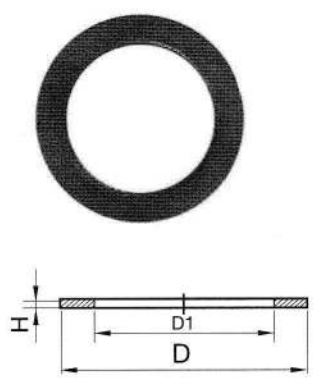

d (mm)	Code	SP	g	D (mm)	D1 (mm)	H (mm)	
40	748 400 309	5	8	59	40	3	
50	748 400 310	5	12	71	50	3	
63	748 400 311	5	17	88	63	3	
75	748 400 312	1	24	104	75	3	
90	748 400 313	1	32	123	90	3	
110	748 400 314	1	62	148	110	4	
125	748 400 315	1	58	168	125	4	
160	748 400 317	1	63	211	160	4	

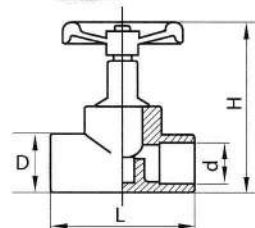

Stop Valve PP-R

6001

- +GF+ AQUASYSTEM
- Polypropylene-Random (PP-R)
- EN ISO 15874, DIN 16962, MS 2206
- Colour: Grey
- EPDM Gasket
- Nickel Coating

d (mm)	Code*	Code* (DZR Brass)	GP	g	L (mm)	H (mm)	D (mm)
20	300 206 832	300 206 835	30	120	72	82	29
25	300 206 833	300 206 836	20	207	84	90	37
32	300 206 834	300 206 837	20	370	104	95	47

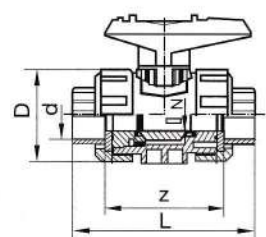

Ball Valve Type 546 PP-H (PN10) with Fusion Socket Metric

6002

- Polypropylene Homopolymeride (PP-H)
- Biggest range of products (via the configurator several executions can be generated)
- Integrated fixation system with mounted threaded inserts
- Ergonomic handle (optional lockable) with integrated tool for dismantling the union bush
- For easy installation and removal

d (mm)	Code (without inserts)	Code (with inserts)	SP	g	D (mm)	L (mm)	z (mm)
20	167 546 002	167 546 402	1	115	50	95	66
25	167 546 003	167 546 403	1	180	58	109	77
32	167 546 004	167 546 404	1	255	68	119	83
40	167 546 005	167 546 405	1	440	84	135	99
50	167 546 006	167 546 406	1	610	97	147	105
63	167 546 007	167 546 407	1	1145	124	168	117

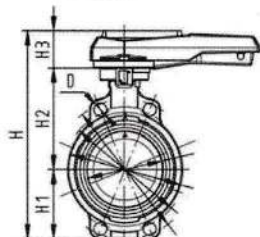

Butterfly Valves Type 567 PP-H (PN10) Hand Lever with Ratchet Settings

6003

- Polypropylene Homopolymeride (PP-H)
- Double internal shaft sealing on both sides
- Double eccentric operating principle
- Standard 5° ratchet setting / fine adjustment as option
- Lockable

d (mm)	Code	SP	g	D (mm)	H (mm)	H1 (mm)	H2 (mm)	H3 (mm)
63	167 567 002	1	969	19	264	77	134	54
75	167 567 003	1	1061	19	277	83	140	54
90	167 567 004	1	1191	19	289	89	146	54
110	167 567 005	1	1751	19	325	104	167	55
160	167 567 006	1	2989	24	373	130	189	55

Ball Valve with Handle

6004

- +GF+ AQUASYSTEM
- EN ISO 15874, DIN 16962
- Polypropylene-Random (PP-R)
- Colour: Beige

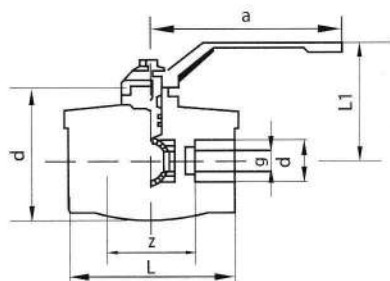

d (mm)	Code	GP	g	L (mm)	a (mm)	z (mm)	L1 (mm)
20	760 840 792	25	115	67.5	102	38.5	60
25	760 840 793	20	135	70.5	102	38.5	60
32	760 840 794	15	190	79.5	102	43.5	63
40	760 840 795	8	350	94	119.5	54	78
50	760 840 796	6	510	109	119.5	63	83
63	760 840 797	3	935	146	146	78	103

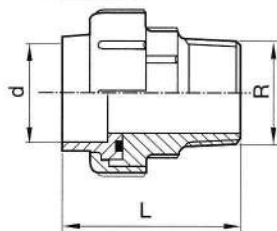

Adaptor Union Male Thread

5015

- +GF+ AQUASYSTEM
- EPDM O-Ring
- Polypropylene-Random (PP-R)
- Colour: Grey

dxR (mm)	Code	Code* DZR	GP	g	L (mm)
20 - 1/2	300 206 702	300 206 690	80	140	52
25 - 3/4	300 206 703	300 206 691	60	160	56
32 - 1	300 206 704	300 206 692	30	220	61
40 - 1 1/4	300 206 705	300 206 693	10	280	76
50 - 1 1/2	300 206 706	300 206 694	10	360	79
63 - 2	300 206 707	300 206 695	6	480	89

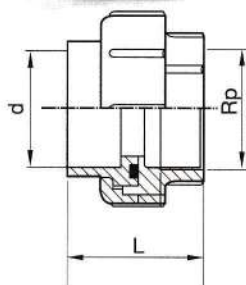

Adaptor Union Female Thread

5016

- +GF+ AQUASYSTEM
- EPDM O-Ring
- Polypropylene-Random (PP-R)
- Colour: Grey

dxRp (mm)	Code	Code* DZR	GP	g (mm)	L
20 - 1/2	300 206 712	300 206 722	80	120	39
25 - 3/4	300 206 713	300 206 723	60	140	41
32 - 1	300 206 714	300 206 724	30	200	43
40 - 1 1/4	300 206 715	300 206 725	10	240	54
50 - 1 1/2	300 206 716	300 206 726	10	320	57
63 - 2	300 206 717	300 206 727	6	440	63

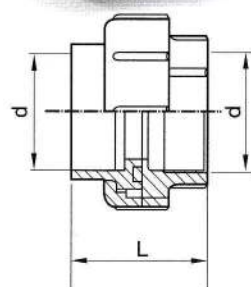

Union Socket-Socket

5017

- +GF+ AQUASYSTEM
- EPDM O-Ring
- Polypropylene-Random (PP-R)
- Colour: Grey

dxRp (mm)	Code	Code* DZR	GP	g (mm)	L
20	300 206 731	300 206 741	80	120	41
25	300 206 732	300 206 742	60	140	45
32	300 206 733	300 206 743	30	200	49
40	300 206 734	300 206 744	10	240	60
50	300 206 735	300 206 745	10	320	66
63	300 206 736	300 206 746	6	440	74



Complete Socket Welder (Set)

7001

- Complete set in a Metal case
- Socket welder with electronic temperature control
- Heating bushes
- Timer
- Fusion marking template
- Floor stand
- Pipe shears
- Instruction Manual

d (mm)	Code	SP	kg		
20-32	300 206 539	1	7.10	230V / 800W	
20-63	300 206 540	1	13.10	230V / 800W	
75-110	300 206 541	1	14.20	230V / 1500W	



Standard Socket Welder

7002

- Socket welder with electronic temperature control
- Floor stand
- Instruction Manual
- Excluding Heating Bushes

d (mm)	Code	SP	kg		
20-63	300 206 518	1	1.80	230V / 800W	
20-110	300 206 519	1	3.55	230V / 1500W	

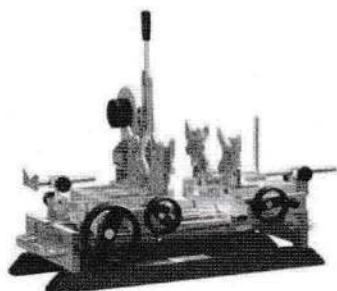

SG 125 Socket Fusion Machine

7003

- Portable socket fusion machine for use in workshop and on job sites
- Dimension d20-d125
- Heater with electronic temperature control
- Excluding Heating Bushes

d (mm)	Code	SP	kg		
20-125	790 310 034	1	65.00	230V / 1500W	



TM 160 ECO Butt Fusion Machines

TM 160 ECO Machine Complete

7004

- Flexible and user-friendly heating element Butt Fusion machine for fusion jointing PE, PP, PB and PVDF pipes and fittings on building sites and in trenches
- Scope of delivery includes: lightweight ECO hydraulic unit, flexible base machine, powerful planer, high performance heating element with electronic temperature control box, storage case for the planer and heater
- Including transport packaging (carton pallet), without accessories and without reduction inserts
- 115 V on request!

Type	d-d (mm)	Performance	Code	kg	
TM 160 ECO	40-160	230V/1900W	790 150 010	86.00	

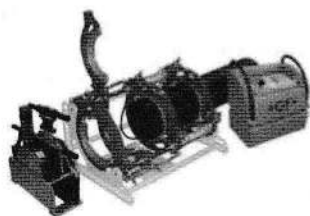

TM 160 TOP Butt Fusion Machines

TM 160 TOP Machine complete

7005

- High quality, flexible and user-friendly heating element Butt Fusion machine for fusion jointing PE, PP, PB and PVDF pipes and fittings on building sites and in trenches
- Scope of delivery includes: innovative TOP hydraulic unit, flexible base machine, powerful planer, high performance heating element, storage case for the planer and heater
- Including transport packaging (wooden crate), without accessories and without reduction inserts

Type	d-d (mm)	Performance	Code	kg
TM 160 TOP	40-160	230V/1900W	790 150 011	125.00

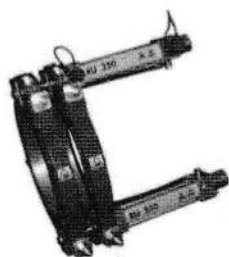

TM 160RU Vertical Installation Unit

7006

- Unit with 2 clamping devices and a pair of cylinders, especially convenient for butt-fusion joints in narrow trenches or inside of buildings and industrial plants.
- Heating element, planer, hydraulic unit and reduction inserts could be used from the corresponding TM machine.

Type	Code	kg
RU 160	790 150 045	8.800



TM 160 Hydraulic Adapter Hose Package

7007

- Flexible hydraulic hoses, with drip-proof, quick-coupling action
- Required when assembling a TM base machine to GF or KL hydraulic units
- Required when connecting a GF or KL base machine to the TM TOP hydraulic unit
- Hoses with quick action couplers (M3/8" – F 1/4", F 3/8" – M 1/4")

Code	kg
790 150 003	3.862

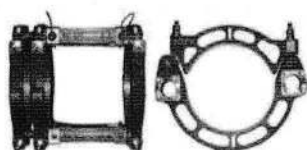

TM 160 RU Outer Clamp

7008

- An additional clamping device can be mounted on the cylinders to improve the alignment of the components to be welded.

Type	Code	kg
RU 160	790 150 046	2.000



TM 160 - 250 - 315 ECO Planer

7009

- Powerful parallel planer for single or double-sided facing of pipe ends
- Reliable torque transmission via robust worm-gear device
- Ergonomic, weight-balanced handling
- Optimised cutting geometry for even and chatter-free planing
- Safely switch to prevent undesired start-up
- Self-locking mechanism in working position
- 115 V on request!

Type	d-d	Performance	Code	kg
TM 160 ECO	40-160	230V/630W	790 150 014	7.000



TM 160 - 250 - 315 Heating Element

7010

- High performance, electronically controlled heating element
- Uniform temperature distribution over the entire heating surface
- High-quality, non-stick PTFE-coating with long service life
- Temperature indicator integrated into the handle
- Easy placement in the correct working position with automatic heater release mechanism
- Self-locking mechanism in working position
- 115 V on request!

Type	d-d	Performance	Code	kg
TM 160	40-160	230V/1200W	790 114 004	5.402



TM 160 - 250 - 315 Case

7011

- For safe storage of planer and heating element

Type	d-d	Code	kg
TM 160	40-160	790 150 295	7.000



TM 160 - 250 - 315 ECO Hydraulic Unit

7012

- Clearly visible, vibration-free pressure gauge with precision scaling
- Compact construction with protection frame
- Fine adjustment of pressure
- High pressure consistency during cooling phase
- Fix attached hydraulic hose
- 115 V on request!

Type	d-d	Performance	Code	kg
TM 160	40-160	230V/1200W	790 150 013	5.402



TM 160 - 250 - 315 ECO Temperature Controller

7013

- Electronic temperature control
- Accurate adjustment (set point) of heating element temperature
- Digital display of current and set-point temperature
- 115 V on request!

Type	d-d	Performance	Code	kg	
TM 160	40-160	230V/1200W	790 152 006	5.402	

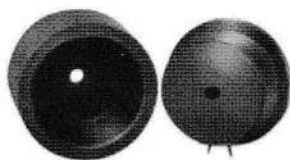

Heating Bushes

7020

- Coated with Polytetrafluoroethylene (PTFE)
- Incrustation Free
- EN ISO 15874, DIN 16962
- Corrosion Free
- Low thermal Conductivity

d (mm)	Code	SP	kg	
20	300 206 561	1m + 1f	0.120	
25	300 206 562	1m + 1f	0.150	
32	300 206 563	1m + 1f	0.210	
40	300 206 564	1m + 1f	0.310	
50	300 206 565	1m + 1f	0.450	
63	300 206 566	1m + 1f	0.600	
75	300 206 567	1m + 1f	0.965	
90	300 206 568	1m + 1f	1.440	
110	300 206 569	1m + 1f	2.210	
125	300 206 570	1m + 1f	2.900	



Hole Mender

7021

- Coated with Polytetrafluoroethylene (PTFE)

d (mm)	Code	SP	GP	
7.5	760 840 481	1m+1f	1m+1f	
11.4	760 840 482	1m+1f	1m+1f	

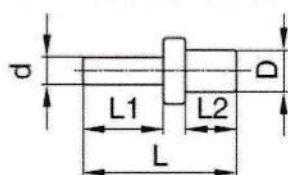

Repairing Hole

7022

- +GF+ AQUASYSTEM
- Polypropylene-Random (PP-R)
- Colour: Beige

d (mm)	Code	GP	g (mm)	D (mm)	L (mm)	L1 (mm)	L1 (mm)	
7.5/11.4	760 840 425	1	4	11.4	42	22	14	



Heating Tools for Saddle with Spigot

7023

- Coated with Polytetrafluoroethylene (PTFE)
- Incrustation Free
- EN ISO 15874, DIN 16962
- Corrosion Free
- Low Thermal Conductivity

d (mm)/(inch)	Code	SP	GP	
40-20-25-1/2	760 840 585	1m+1f	1m+1f	
50-20-25-1/2	760 840 586	1m+1f	1m+1f	
63-20-25-1/2	760 840 587	1m+1f	1m+1f	
75-20-25-1/2	760 840 588	1m+1f	1m+1f	
90-20-25-1/2	760 840 589	1m+1f	1m+1f	
110-20-25-1/2	760 840 590	1m+1f	1m+1f	
125-20-25-1/2	760 840 591	1m+1f	1m+1f	
50-32-40-3/4 -1	760 840 592	1m+1f	1m+1f	
63-32-40-3/4	760 840 593	1m+1f	1m+1f	
75-32-40-3/4 -1	760 840 594	1m+1f	1m+1f	
90-32-40-3/4 -1	760 840 595	1m+1f	1m+1f	
110-32-40-3/4 -1	760 840 596	1m+1f	1m+1f	
125-32-40-3/4 -1	760 840 597	1m+1f	1m+1f	



Milling Cutter for Saddles with Spigot

7024

- Coated with Polytetrafluoroethylene (PTFE)

d (mm)/(inch)	Code	SP	GP	
20-25-1/2	760 840 600	1	1	
32-3/4	760 840 601	1	1	



Timer

7025

d (mm)	Code	SP	kg	
	761 066 798C	1	0.042	

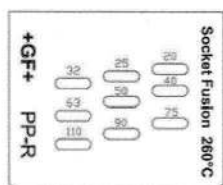

Welding Template

7026

d (mm)	Code	SP	kg	
20-10	300 206 530	1	0.040	



Pipe Shears

7027

d (mm)	Code	SP	kg	
20-32	300 203 161	1	0.472	



Pipe Cutter

7028

d (mm)	Code	SP	kg	
20-75	760 840 505	1	0.800	
50-110	300 206 506	1	1.400	

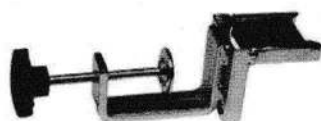

Table Stand

7029

d (mm)	Code	SP	kg	
	300 147 941	1	0.860	

Chamfering and Peeling Tool for PP-R Pipes

7030



d (mm)	Code	GP	
20	760 840 822	1	
25	760 840 823	1	
32	760 840 824	1	
40	760 840 825	1	
50	760 840 826	1	
63	760 840 827	1	
75	760 840 828	1	
90	760 840 829	1	
110	760 840 830	1	



Handle for Chamfering

7031

20/32	760 840 818	1	
-------	-------------	---	--



Side Handle

7032

40/110	760 840 819	1	
--------	-------------	---	--

Pipe clamp

7033

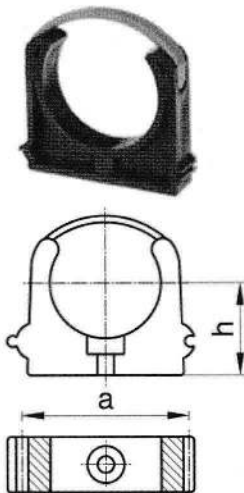

d (mm)	Code	SP	GP	g (mm)	a (mm)	h (mm)	
20	167 061 036	10	200	8	36	25	
25	167 061 037	10	200	10	41	27	
32	167 061 038	10	200	13	51	31	
40	167 061 039	10	150	23	62	35	
50	167 061 040	10	140	32	72	40	
63	167 061 041	10	80	45	88	52	
75	167 061 012	10	60	62	102	58	
90	167 061 013	10	-	91	123	70	
110	167 061 014	10	-	123	146	80	
125	167 061 015	10	-	174	176	90	



Plan Test Plug

7034

d (mm)	Code	SP	kg
1/2	300 206 533	1	0.001



KS Tangit Cleaner

7035

d (mm)	Code	SP	kg
	799 298 023	1	0.890



MSA 330

MSA 330 Electrofusion unit with jointing data recording

7036

The MSA 330 electrofusion unit combines high performance in jointing with easy and safe handling. The internal memory has a capacity of 500 jointing records, for data transfer the unit is equipped with a USB interface. The record is delivered as PDF or CSV format, both are manageable with common and free PC software applications.

An intuitive operation menu guides you through the complete jointing process. For fusion data input a barcode reader pen or a scanner is connected. The entire welding process is controlled and regulated with energy output compensation depending on ambient temperature and the indication of cooling time. Robust aluminum housing with convenient cable winding and handle for weight balanced transport. The unit is suitable for jointing in series.

Scope of delivery: dedicated transport case, pouch for optical pen or scanner, 2 pairs of angle adapter clips 4,0mm and 4,7mm, operation instructions and configuration chart.

Technical Data

- Ambient temperature: -10°C to + 45°
- Mains voltage: 180V – 265V AC
- Mains frequency: 40Hz-70Hz
- Fusion voltage: 8-48 V AC
- Fusion current: max.90 A
- Suggested power generator: 3,5kVA (5,0kVA for fittings with Ø → 200mm)
- Protection Class: 1/IP 54
- Mains cable: 4m
- Fusion: 4m
- Interface: USB (typeA) for PC communication and software updates
- Dimensions (WxHxD): 280 x 480 x 320 mm
- Weight incl. cables: ca. 21,7kg
- Display: LCD (20 alphanumerical char. X4 lines), contrast adjustment, blue background, white characters
- Languages: 10

Description	Code	kg
Barcode reader pen, transport case	790 160 004	30
Barcode scanner, transport case	790 160 005	30

Precautions

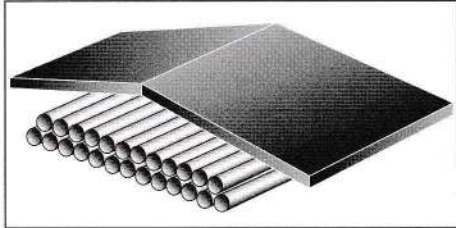

UV Rays

To avoid damage from UV Rays, PP-R shall not be exposed to direct sunlight.

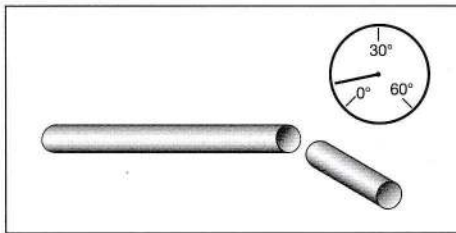

Low Temperatures

Plastics can become brittle at low temperature. Installation shall be performed at temperature above 0°C. Knocks and impacts shall be avoided at temperature below -5°C.

We suggest to cut the pipe end of 5 cm.

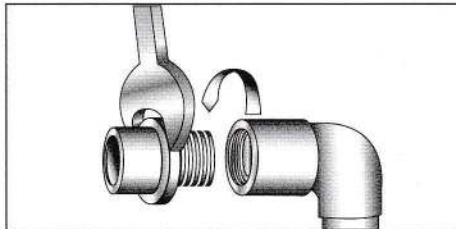

Threaded Fittings

The threaded fittings are recommended to be joined with Polytetrafluoroethylene (PTFE) tape. The thread shall not be over tightened as the plastic parts may be damage.

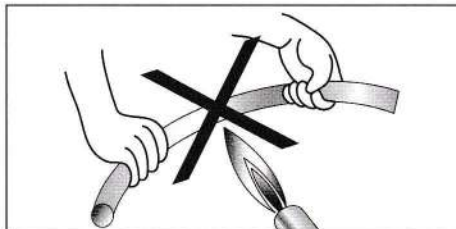

Pipes Bending

The minimum bending radius must be equal or more than 8 times of the pipe diameter. For this purpose, heat the part which will be bent by using a industrial heat blower or suitable equipment. Do not use flame.

WE HIGHLY RECOMMEND TO CONTACT OUR TECHNICAL SUPPORT FOR ADVICE ON PIPE BENDING.

Working with plastic pipes & fitting

Transport and storage of plastic pipes

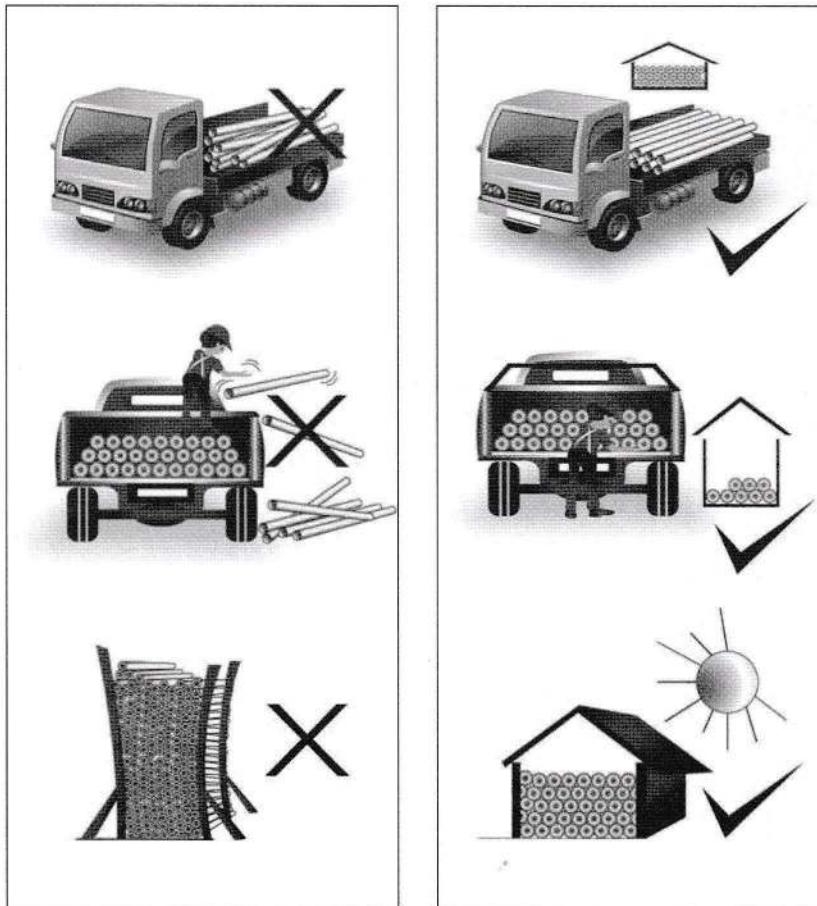

Plastic are materials sensitive to impact and crushing at low temperatures. The temperature limit depends on the relevant material.

Material	Temperature
PP-R	-5C
PVC-C	+5C
PB	0C
PE	-40C
PE-RT	-40C

Below these temperatures pipes and fittings would have to be protected particularly from impacts, crushing and other external mechanical stresses.

Plastic pipes and plastic fittings must be protected in principle from external influences. Direct sunlight, impacts and compressive stresses should be avoided. The pipes and fittings must be left in their packing until used. They should not be stored outdoors.

Selection of Pipe Diameter

In order to select the best water flow depending on the available water pressure and corresponding usage, please refer to the table here below:

Table for the selection of pipes diameters and water flow

Water Connection Point	Flow (l/sec).	Pressure (bar)	Pipe Diameter (mm)
Wash Basin			
Tap DN 15	0.07	0.50	20
Mixer Tap DN 15	0.07	1.00	20
Bidet			
Tap DN 15	0.07	0.50	20
Mixer Tap DN 15	0.07	1.00	20
Bath tub			
Mixer Tap DN 15	0.15	1.00	20
Mixer Tap DN 20	0.40	1.00	25
Mixer Tap DN 25	1.00	1.00	32
Shower			
Sprinkler DN 15	0.15	1.00	20
Sprinkler DN 15	0.06	1.00	20
Sprinkler DN 20	0.18	1.00	20
Sprinkler DN 25	0.31	1.00	20
Flush and flushing tank			
Flush DN 20	1.00	1.20	32
Flush Tank DN 15	0.13	0.50	20
Electric and gas boilers			
6 kW	0.07	1.00	20
12kW	0.10	1.00	20
18kW	0.15	1.00	20
21kW	0.17	1.00	20
24kW	0.20	1.00	20
33kW	0.30	1.00	20
Sinks			
Mixer DN 15	0.07	1.00	20
Mixer DN 20	0.02	1.00	20
Dishwashers Washing Machines			
	0.15	1.00	20
	0.25	1.00	20
Urinals			
Flush DN 15	0.30	1.20	20
Flushing Tank DN 15	0.13	0.50	20

Assessment of Pressure

The pressure losses for distribution in the Georg Fischer piping system can be assessed by means of the following chart or by means of the following formula:

$$\Delta p = \lambda \cdot \frac{L \cdot \rho \cdot v^2}{d_i \cdot 2 \cdot 10}$$

- Where:
- Δp pressure loss in a straight pipe (bar)
 - λ pipe friction factor (in most cases 0.02 is sufficient)
 - L length of straight pipe (m)
 - ρ density of transported media (kg/m³)
 - v flow velocity (m/s)
 - d_i inside diameter of pipe (mm)

Loss Pressure Diagram for PN 20 Pipe

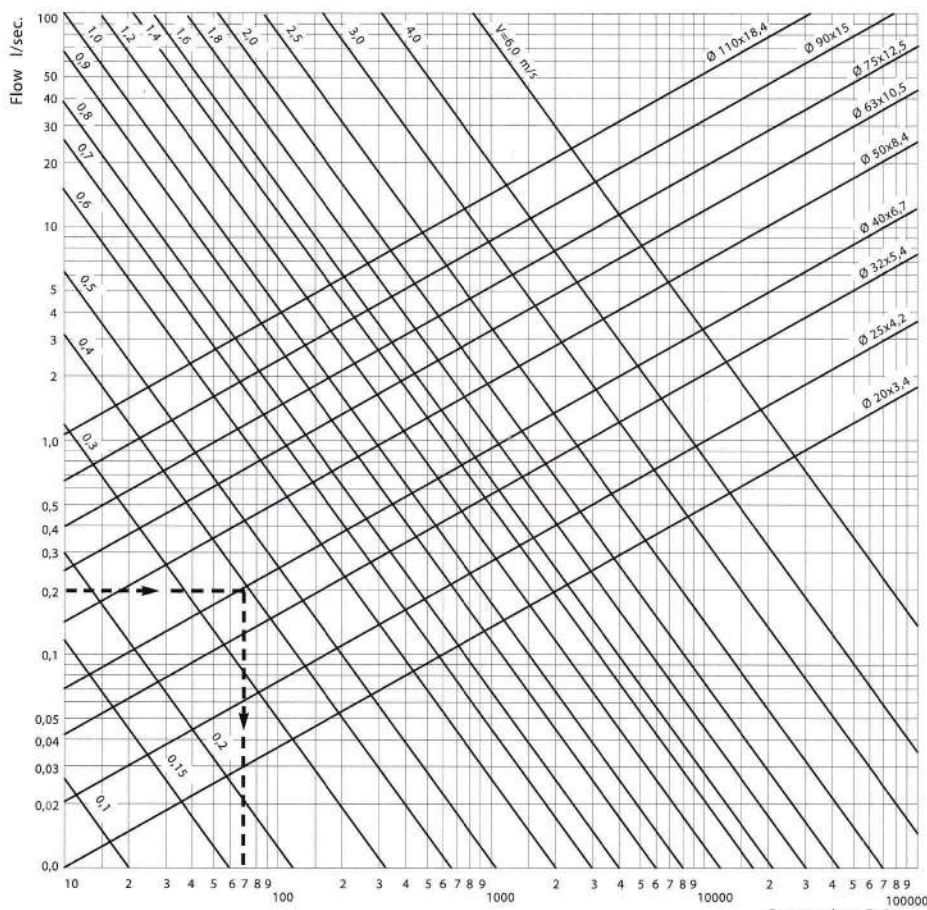

Example:

Pipe: 40 X6.7 mm
 Flow = 0.2 l/s
 Water velocity = 0.4 m/s

From the diagram,
 Pressure loss
 = 70 Pa/m
 = 0.7 mbar
 (10,000 Pa = 0.1 bar = 100 mbar)

Assessment of Pressure

Loss Pressure Diagram for PN 10 Pipe

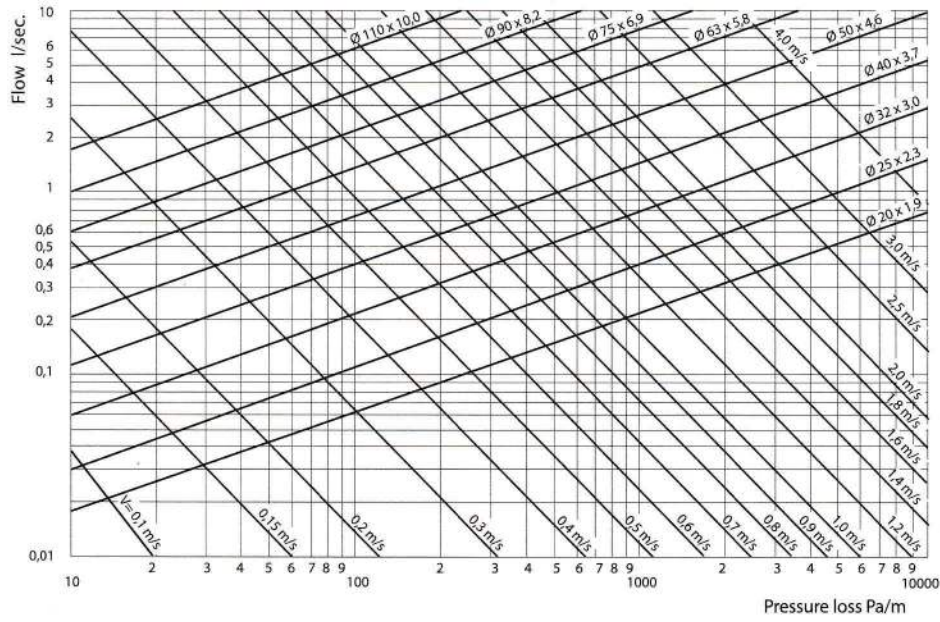

Assessment of Pressure

Pressure Losses in Georg Fischer Fittings

Description	Symbol	Coefficient of resistance
Equal coupling		0.25
Elbow 90°		2.00
Elbow 45°		0.60
Equal tee 90°		1.80
Reduced tee 90°		3.60
Equal tee 90°		1.30
Reduce tee 90°		2.60
Equal tee 90°		4.20
Reduced tee 90°		9.00
Equal tee 90°		2.20
Reduce tee 90°		5.00
Threaded tee 90°, male		0.80
Concentric reductions up to 2 size		0.55
Concentric reductions up to 3 size		0.85
Threaded fitting, male		0.40
Threaded fitting, male, reduced		0.85
Threaded elbow, male		2.20
Threaded elbow, male, reduced		3.50

Example:

Assume we have a water services system with the following characteristics:

- pipe diameter 25 mm
- total pipe length 10 m
- fittings used:
 - 4 coupling
 - 3 elbows 90°
 - 2 equal tees
 - 1 threaded coupling, male
- velocity 1.5 m/s
- flow rate 0.35 l/s
- T = 20°C

From the table,

- ξ₁ (coupling) = 0.25 x 4
- ξ₂ (elbow 90°) = 2.00 x 3
- ξ₃ (equal tees) = 1.80 x 2
- ξ₄ (threaded coupling, male) = 0.40 x 1

Total ξ = 11

$$\text{Total } P = \Delta p + H$$

From graph above,
 $\Delta p = 1100 \text{ Pa/m}$
 = 11 mbar

For 10m length pipe,
 $\Delta p = 11 \times 10$
 = 110 mbar

$$H = 10 \cdot \frac{\xi \cdot v^2 \cdot \rho}{2g}$$

where:

H = pressure losses in fittings

v = water velocity (m/s)

g = specific graving of water (kg/m³)

= 9.8 m/s²

ξ = coefficient of resistance

$$H = \frac{10 \times 11 \times 1.5^2 \times 1000}{2 \times 9.8}$$

= 12630 Pa

= 126 mbar

$$\text{Total } P = H + \Delta p$$

= 110 + 126

= **236 mbar**

Regression Curve

The regression curves affect pipe life depending on the fluid pressure, temperature and outer stress (see chart).

Regression curves

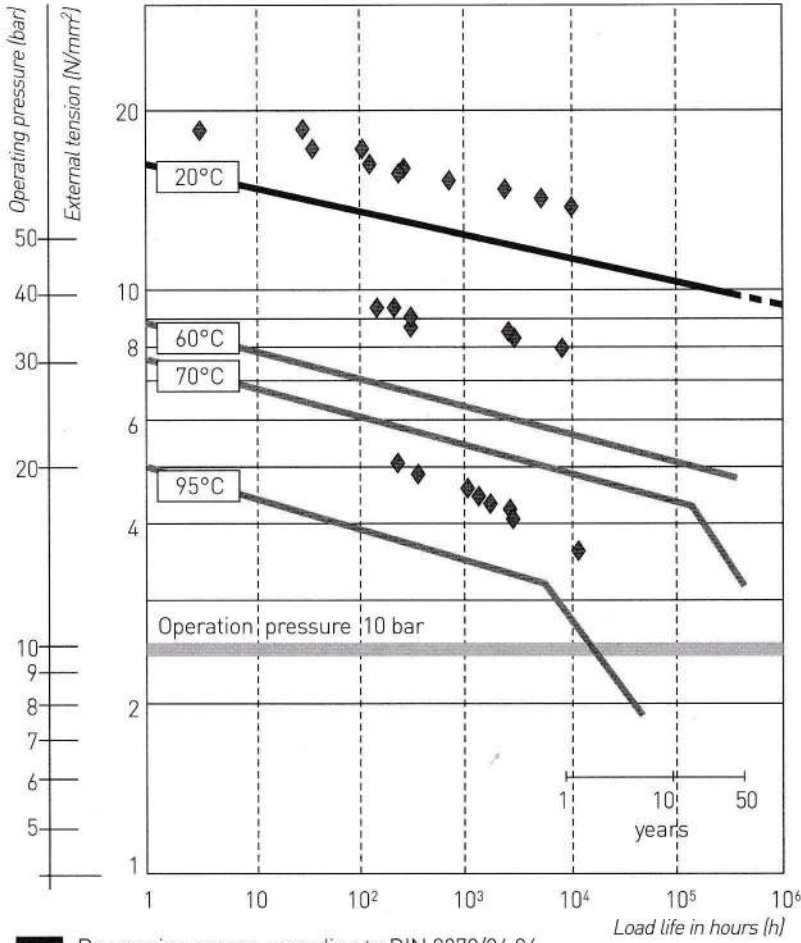

The diagram shows the lowest life features according to DIN 8078 standards and life test results concerning the polymer used, in order to confirm the high resistance to pressure and temperature of AQUASYSTEM

— Regression curves according to DIN 8078/04.94

◆ Actual data of PP-R measured with PN 20 pipes

Hydrostatic stress:

Expressed in megapascals, induced in the wall of pipe when a pressure is applied using water as a medium.

Using Hydrostatic stress and dimensions, the maximum working pressure can be calculated with the following equation:

The formula joining these parameters is : $R = P \times \frac{d - s}{2s}$

P = maximum inner pressure
 d = outer diameter
 s = thickness
 R = outer stress

Example

T = 60°C Continuous operating life: 50 years
 From the regression curve the result is: R = 4,9 Mpa

Calculation (from the formula)

P = 19,7 bar

Or P = 13 bar

(using safety coefficient of 1.5)

technical features

Permissible Operating Pressure

Water Temperature	Working years	Type of pipe		
		PN 10	PN 16	PN 20
		SDR 11	SDR 7.4	SDR 6
		S 5	S 3.2	S 2.5
Pressure bar				
10°C	1	17.6	27.8	35.0
	5	16.6	26.4	33.2
	10	16.1	25.5	32.1
	25	15.6	24.7	31.1
	50	15.2	24.0	30.3
20°C	1	15.0	23.8	30.0
	5	14.1	22.3	28.1
	10	13.7	21.7	27.3
	25	13.3	21.1	26.5
	50	12.9	20.4	25.7
30°C	1	12.8	20.2	25.5
	5	12.0	19.0	23.9
	10	11.6	18.3	23.1
	25	11.2	17.7	22.3
	50	10.9	17.3	21.8
40°C	1	10.8	17.1	21.5
	5	10.1	16.0	20.2
	10	9.8	15.6	19.6
	25	9.4	15.0	18.8
	50	9.2	14.5	18.3
50°C	1	9.2	14.5	18.3
	5	8.5	13.5	17.0
	10	8.2	13.1	16.5
	25	8.0	12.6	15.9
	50	7.7	12.2	15.4
60°C	1	7.7	12.2	15.4
	5	7.2	11.4	14.3
	10	6.9	11.0	13.8
	25	6.7	10.5	13.3
	50	6.4	10.1	12.7
70°C	1	6.5	10.3	13.0
	5	6.0	9.5	11.9
	10	5.9	9.3	11.7
	25	5.1	8.0	10.1
	50	4.3	6.7	8.5
80°C	1	5.5	8.6	10.9
	5	4.8	7.6	9.6
	10	4.0	6.3	8.0
	25	3.2	5.1	6.4
95°C	1	3.9	6.1	7.7
	5	2.5	4.0	5.0

DIN 8077 edition 07/1999 - coefficient factor 1.5

Thermal Expansion & Contraction

Thermoplastics are subject to greater thermal expansion and contraction than metals. Pipes installed above ground, against walls or in ducts, especially those exposed to temperature variations, require changes in length to be absorbed in order to prevent strain on the pipes. Length changes can be absorbed by:

- a) Flexible sections
- b) Compensators

Flexible sections are the most common solution, being the simplest and the most economical. Calculation of the positioning of flexible section are therefore described in detail.

Calculation of change in length

During the design and installation of plastic pipes, it is very important to calculate the expansion caused by the possible difference between operating temperature and installation temperature.

The change in length is calculated with the following formula:

$$\Delta L = L \times \Delta T \times \alpha$$

Where:

ΔL = change in length (mm)

L = initial pipe length (m)

ΔT = temperature difference (°C)

α = expansion coefficient (mm/m°C)

The expansion Coefficient

α indicates the elongation of a 1m pipe under a temperature increase of 1°C

Medium thermal expansion coefficient for PP-R pipelines :

$$\alpha = 0.15\text{mm/m}^\circ\text{C}$$

Example

Changes in length for PP-R pipe:

$L=5\text{m}$

$\Delta T=50^\circ\text{C}$

$\alpha = 0.15\text{mm/m}^\circ\text{C}$

$$\begin{aligned} L &= 5 \times 50 \times 0.15 \\ &= 37.5\text{mm} \end{aligned}$$

Position of the Flexible Arms

The low modulus of elasticity of thermoplastics allows changes in length to be absorbed by special pipe sections where pipe supports are positioned so that they can take advantage of the natural flexibility of the material.

The length of such sections is determined by the diameter of the pipeline and the extent of the thermal expansion to be compensated.

In order to simplify design and installation, the temperature of the pipe wall, a third factor, will not be taken into account, especially since most pipes are installed in an environment with ambient temperature in the range of 5 to 30°C.

Arrangement of fixed point support clamps (PF)

Fixed points direct thermal expansion of the pipe in the desired direction. Fixed points should always be installed at the fitting and should support it on both sides or be installed in between two fittings.

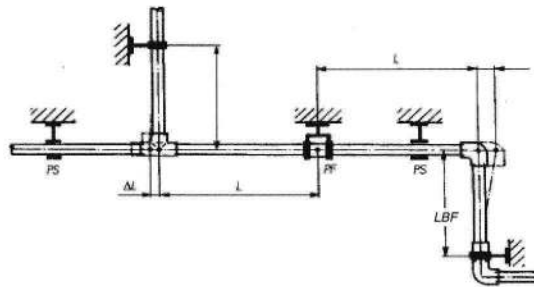

Sliding support clamps (PS)

Sliding fasteners allow an axial movement of the pipe. The clamp must be in line with the pipe. Sliding clamps must be lined with rubber inserts suitable for plastic pipe movement to avoid pipe damage.

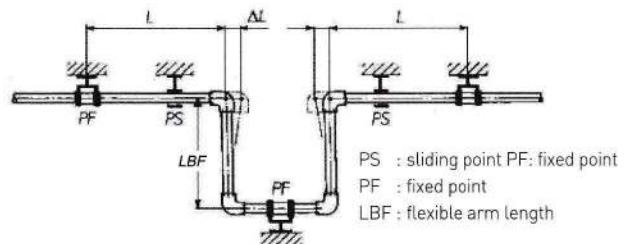

Example for the assessment of the flexible arm

Data: $L = 10 \text{ m}$
 $d = 50 \text{ mm}$
 $T_{\text{installation}} = 15 \text{ }^{\circ}\text{C}$
 $T_{\text{max operation}} = 80 \text{ }^{\circ}\text{C}$
 $\Delta L = 0,15 \cdot 10 \cdot 65 = 97,5 \text{ mm}$

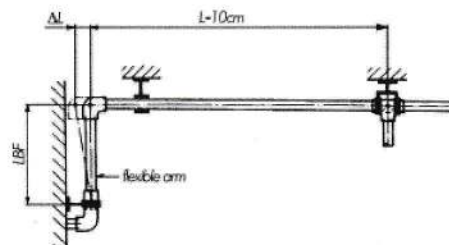

Position of the Flexible Arms

Assessment of the flexible arm for PP-R pipe

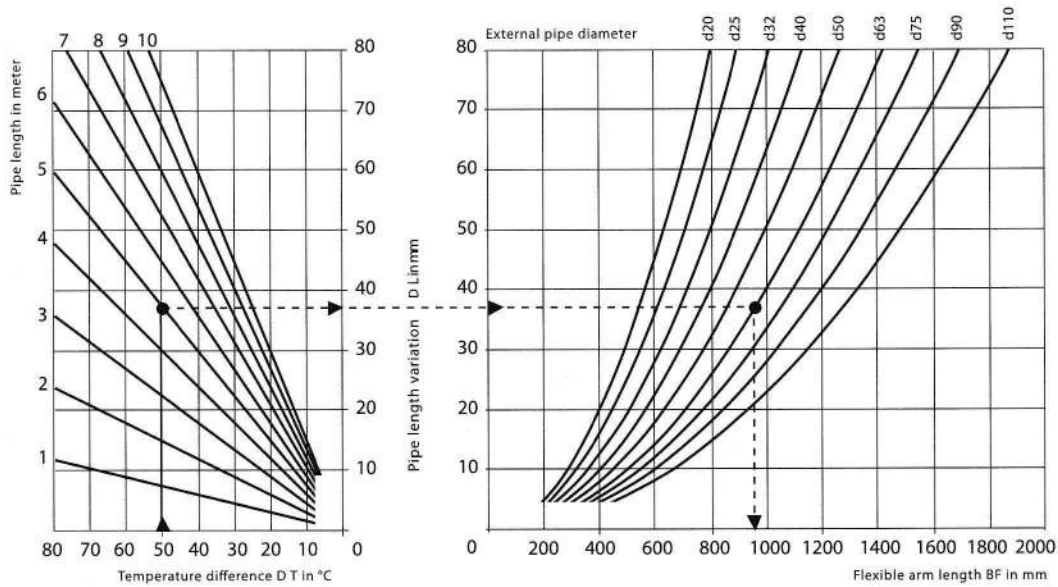

$$L_{BF} = C \times \sqrt{\Delta L} \times d_e$$

L_{BF} = flexible arms length
 C = constant PP-R = 20
 ΔL = change in length (mm)
 d_e = outer pipe diameter

Example

What is the flexible arms length if the expansion ΔL is 37 mm on a d63 pipe?

$$L_{BF} = 20 \times \sqrt{37} \times 63 = 966\text{mm}$$

Insulation & Thermal Conductivity

+GF+ AQUASYSTEM for Polypropylene – Random (PP-R) pipes and fittings are designed to have low thermal conductivity. Generally it would not be required to install thermal insulations for concealed or exposed pipes and fittings within an enclosed environment. However insulation may be needed, depending on the countries regulations, warm or cold application or that of energy-saving requirement. Insulation guidelines, as per DIN 1988, depends on the respective installation; the use of hot or cold water and the wall thickness.

Thermal conductivity

There is a time-dependent transfer of heat (Q) between two points of a body which have different temperatures. Considering a wall of cross-sectional area A and thickness e, the heat conducted from one side to the other is directly proportional to the (maintained) temperature difference between the sides, to the area A and to the time t, It is inversely proportional to the thickness e:

$$Q = \lambda \cdot A \cdot t \cdot \Delta T / e$$

The constant of proportionality k depends on the wall's material and is called its coefficient of thermal conductivity.

$$[\lambda] = W / (m \cdot K) = Wm^{-1} K^{-1}$$

W = watt, m = meter, K = Kelvin (= °C)

Substance	Coefficient of thermal conductivity [Wm ⁻¹ K ⁻¹]
Foam Plastics	0.02 - 0.05
PVC-U	0.16
PVC-C	0.17
PP	0.22
PE-HD	0.41
Copper	400
Water	0.61
Air	0.023

Cold Water

Type of Installation	Guidelines value for minimum thickness of insulation for cold water system $\lambda = 0.040$ w/mK
Exposed installed Pipe in a unheated room (e.g cellar)	4 mm
Exposed installed Pipe in a heated room	9 mm
Pipes installed in a channel without additional heated pipelines	4 mm
Pipes installed in a channel besides additional heated pipelines	13 mm
Pipes installed in building slit / Raising main	4 mm
Pipes installed in wall recess next to heated pipelines	13 mm
Pipes laid on cement floor	4 mm

The insulation thickness, applied to a diameter of d = 20mm, for other coefficients of thermal conductivity have to be calculated correspondingly. (DIN 1988 PART 2)

Thermal Conductivity for Hot Water

Based on 60°C water temperature and environment temperature of 30°C per meter (unit in J/s)

Dimension		20	25	32	40	50	63	75	90	110	125	160
Material	PP-R PN 20	99.84	101.31	100.75	101.69	102.82	108.62	102.31	102.31	102.54		
	PP-R PN 16	126.29	126.29	129.00	129.00	128.45	130.11	129.19	129.93	129.26	129.73	129.70

- Calculation is not considered the friction factor, head loss and any other factor that could effect on the fluid temperature. Calculation is based on steady state condition
- Theoretical value may differ from the actual condition

Installation Recommendations

Direct embedding of PP-R pipes

PP-R pipes can be embedded directly in concrete. The pipes can withstand the additional axial strains, which occur due to impeded expansion. In such cases, the stress present in the pipe and fittings must be calculated to prevent too high internal stress. It is important to prevent any exposed pipes when the pipe is covered with mortar.

Indirect embedding of PP-R pipes

Where pipework is installed under plaster or embedded into concrete, the flexible sections at bends and branches must be padded for the calculated distance a , as also the branches and elbows in the affected section.

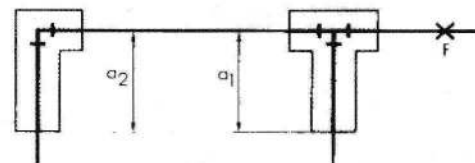

Installing compensators

The low modulus of elasticity means that the reaction force of plastic pipes to thermal changes is low compared to metal pipes. This makes normal compensators designed for use with metal pipes unsuitable because of their high inherent resistance. Only freely moving compensators may be considered: rubber compensators, PTFE-corrugated compensators or suitable selected metal multi-disc compensators.

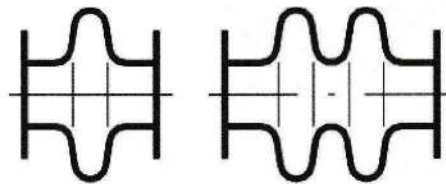

Pipes brackets

Plastic pipes need regularly space support* (see blow table), the bracket distance depends on many factors such as temperature, pressure, diameter and material. In every case, the inner diameter of the support must be greater than the external diameter of the pipe, so as to permit pipe movement due to pipe expansion.



PP-R PN 20/ PN 16/ PN 10 Bracket Spacing distance between two brackets in cm

d [mm]	PN 10	PN 16		PN 20	
	20°C	30°C	40°C	50°C	60°C
20	75	75	70	65	60
25	85	85	85	80	75
32	100	100	95	90	85
40	110	110	105	100	95
50	130	125	115	110	105
63	150	145	140	125	120
75	170	165	160	150	145
90	180	175	170	165	160
110	190	185	175	170	165
125	195	205	170	-	-
160	210	210	180	-	-

Electro Fusion Installation

Welding can be made by using +GF+ electrofusion machine. This machine is also use in repair works, where it is difficult to use the standard machine and where there is space constraint.



Pay attention to the following instructions:

1. Wipe the coupling area of the pipe with a clean cloth. Scrap the fusion area with a appropriate peeling tools to remove contaminated layer of the pipe. Check the pipe ovality (< 1.5%).



2. Thoroughly clean the fittings and pipes with a lint-free tissue with a suitable plastic pipe cleaner.



3. Unpack the fitting and position it on the pipe, so that the sleeve-end matches the pipe-end. Insert the end of the other pipe. Make sure that both ends of the pipe are lined up and secure the fitting and the pipe.



4. Fix the electrofusion machines cables so that the cables do not weigh on the clamps. Connect the clamps to the resistor terminals on the fitting and make sure that the connection is correct. Follow the instructions to program and operate the welding machine.

Minimum cooling time without moving sleeve and pipe

d mm	minutes	d mm	minutes
20	10	63	20
25	10	75	25
32	10	90	30
40	15	110	35
50	15	125	40

about 2 hours hardening time must be allowed from when the fitting is cool before any pressure tests can be used.

Socket Fusion Installation

Preparation

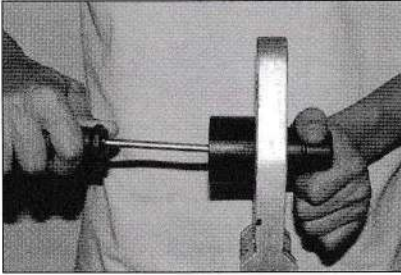

1. Fix heating bushes

Attach the heating bushes on the heating tool. Maximum two set of bushes can be attached at the same time.



2. Check the Temperature

Once the socket fusion machine is turned on, set the temperature on the electronic display which must range between 255°C and 265°C. To ensure correct temperature, regular calibration is recommended.

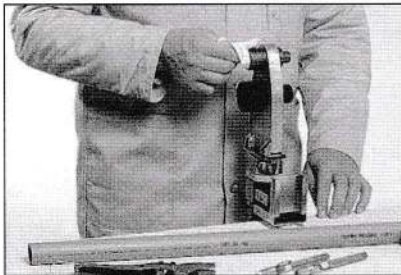

3. Clean the heating tools

After checking the temperature, wipe the heater bush with a clean cloth. This process must be repeated after each welding.

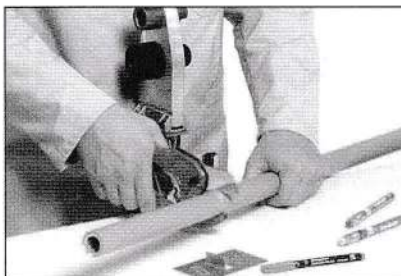

4. Cut the pipe

Cut the pipe at right angle; if necessary remove burrs from inside. If necessary cut deformed or damaged pipe ends of 5 cm.



5. Clean pipe & fitting

Clean the fittings sockets on the inside and the outer wall of pipe (the presence of dust, grease or other impurities can affect the fusion quality and lead to weak jointing).

Socket Fusion Installation

Fusion



1. Mark the pipe

Mark the insertion depth on the pipe for (see table).
The mark must remain visible under heating and jointing.

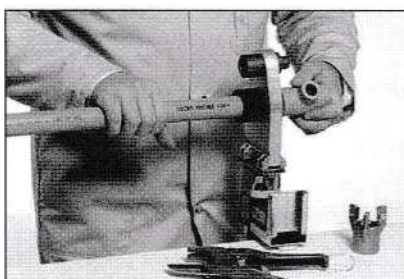

2. Heat pipe & fitting

Push the pipe and the fitting straight into the heating bushes. Pull out the pipe and fitting slowly and without twisting once the heating time has elapsed.



3. Joint pipe & fitting

Push the pipe into the fitting so that the welding beads of pipe and fitting touch together. During the jointing time, small adjustment in angle and alignment can be made. During the cooling time, any stress on the joint must be avoided.



4. Fusion inspection

The outer fusion bead must be inspected. A double bead must be uninterrupted all around the pipe circumference.

Summary Value table

Pipe Diameter (mm)	minimum wall thickness (mm)	insertion depth (mm)	heating time (sec.)	jointing time (sec.)	cooling time (min.)
20	3.4	14	6 (5 sec. for PN 10)	4	2
25	4.2	16	7	4	3
32	5.4	18	8	6	4
40	6.7	20	12	6	4
50	8.4	23	18	6	5
63	10.5	26	25	8	6
75	12.5	28	30	8	8
90	15.0	31	40	10	8
110	18.4	33	50	10	8
125	20.8	40	60	10	8

Butt Fusion Installation

Butt Fusion Jointing of PP Piping Systems

The principle of fusion jointing

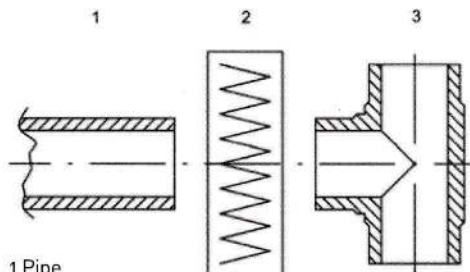

- 1 Pipe
- 2 Heating element
- 3 Fitting

Butt fusion jointing method

The fusion areas of the pipes and fittings are heated to fusion temperature and joined by means of mechanical pressure, without using additional tools. A homogeneous joint results. Butt fusion must only be carried out with fusion jointing machines which allow the jointing pressure to be regulated. Details of the requirements for machines and equipment used for butt fusion jointing thermoplastics are contained in DVS 2208 Part 1. The drawing to the left illustrates the principle of fusion jointing.

General requirements

The basic rule is that only similar materials can be fusion jointed. For best results, only components which have a melt flow index in the range from MFR 190/5 0.4 to 1.0 g/10 min should be fusion jointed. This requirement is met by PP butt fusion fittings from GF. The components to be jointed must have the same wall thicknesses at the fusion area. Butt fusion jointing may only be performed by adequately trained personnel.

Join only components with similar wall thicknesses

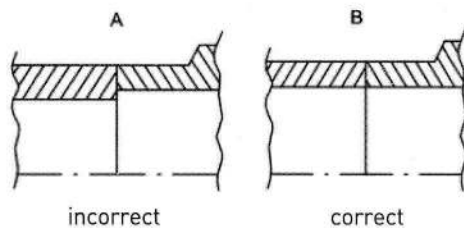

Check the temperature

Recommended temperature of heating element between 200°C to 220°C. Check temperature before commencing the fusion jointing, this is best carried out with the use of a digital thermometer with a sensor for measuring surface temperature.

To ensure the right temperature setting should be checked from time to time during the jointing work. The temperature of the heating element is particularly sensitive to ambient temperature and drafts.

Butt Fusion Installation

Join and cool

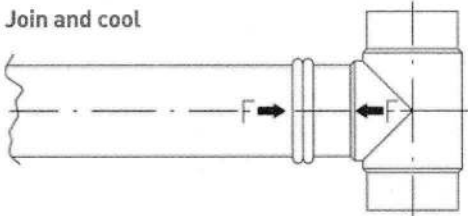

Leave parts in the fusion joining machine at fusion pressure until the end of the cooling period!

Fusion check

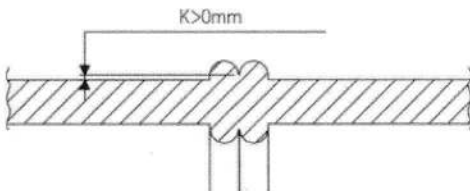

A bead should form around the entire circumference of the pipe. K in the diagram to the left should always be positive.

Fusion joining procedure

Once it has attained the fusion temperature, position the heating element in the fusion joining machine. Press the surfaces to be joined against the heating element with the force required for equalisation until the entire circumference of each of the joining faces rests completely against it and a bead (see the table) has formed. Reduce the equalisation pressure almost to 0 ($p \sim 0.01 \text{ N/mm}^2$). The heating time listed in the table is measured from this moment.

Once the heating period has elapsed, remove the parts from the heating element which should then be removed without touching the joining surfaces and push the heated surfaces together immediately. The changeover time must not exceed the value listed in the table. Pay particular attention during jointing that the parts be moved together swiftly until the surfaces are about to touch. Then they should be moved together so that they are in contact along the entire circumference. Next the pressure should be increased rapidly to the present jointing pressure within the period of time specified in the table. This pressure must be maintained during the entire cooling period. Adjustment may be necessary, especially shortly after the jointing pressure has been attained.

The jointed parts must stay in the fusion joining machine under jointing pressure until the end of the cooling period specified in the table.

Carrying out the pressure test

All fusion joints must be allowed to naturally cooled completely before pressure testing, i.e. as a rule wait about 1 hour after the last joint has been completed.

Approximate values for Butt Fusion of PP 1)

Wall thickness (mm)	Equalisation at $p=0.10 \text{ N/mm}^2$ Height of bead (mm)	Heating time ²⁾ $p=0.01 \text{ N/mm}^2$ (sec)	Changeover time max. (sec)	Time to reach full jointing (sec)	Cooling time ²⁾ under jointing $p=0.10 \text{ N/mm}^2$ (min)
up to 4.5	0.5	up to 135	5	6	6
4.5 - 7	0.5	135 - 175	5 - 6	6 - 7	6 - 12
7 - 12	1.0	175 - 245	6 - 7	7 - 11	12 - 20
12 - 19	1.0	245 - 330	7 - 9	11 - 17	20 - 30
19 - 26	1.5	330 - 400	9 - 11	17 - 22	30 - 40
26 - 37	2.0	400 - 485	11 - 14	22 - 32	40 - 55

- For exact welding value please refer to our technical support team.
- In accordance with DVS 2207-11

Hole Repairing

In case of accidental drilling it is possible to repair the pipe as follows:

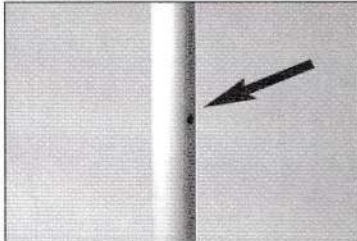

1. Ensure that the hole to be repaired matches the dimensional size of the hole mender. The Repairing Hole Tool comes in 7mm and 11mm, able to repair a hole of 6mm and 10mm.

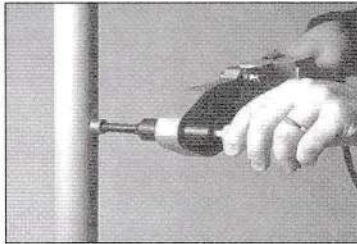

2. Proceed with the normal fusion by heating the two parts for 5 seconds with an appropriate heating element. In relation to the thickness of the pipe, position the Repairing Hole Tool perpendicular to the pipe. The heating element must range between 255°C and 265°C before jointing.

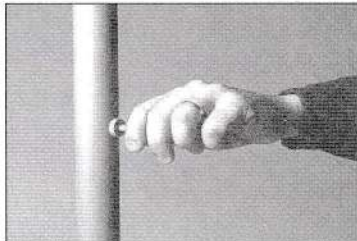

3. Insert the pre-heated Repairing Hole into the pre-heated hole of the pipe. Remain in perpendicular position to the pipe for a while for cooling purpose.

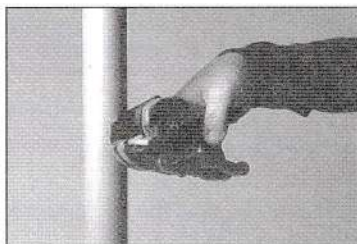

4. Wait until the cooling time is complete before cutting the excess part.

Saddles Installation

Assemble the special heating tools for saddles with a standard socket welder. Once the socket welder is on, check the temperature, which must be in the range of 255-265°C (this operation may be performed by means of thermostatic sticks). Wipe the heating tools with a clean clothe. Clean the surfaces to be welded by means of light specific solvent (TANGIT KS).



1. Scrap the pipe surface with a scraper. With PPR pipes, the aluminium layer must be removed.



2. Drill the pipe with the specific drill bit, taking into consideration the saddle spigot diameter. The chip has to be taken out to avoid any pipe contamination. It is possible to smoothen the hole mouth by changing the drill in counter clockwise direction.



3. Push the saddle heating tool with the spigot into the pipe hole and the saddle into the other tool. Heat the pipe surface and the saddle for 30 seconds.

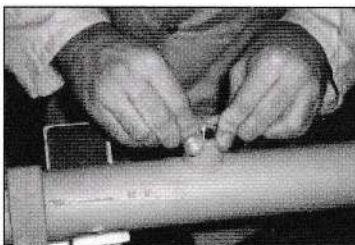

4. Once the heating process is over, remove the socket welder and push the saddles spigot into the pipe hole with a light pressure until the surfaces will meet entirely. Hold the position for 15-20 seconds and let the system cool down for 30 min, before making the pressure test.

Saddles Installation

Welding Parameter

Diameter pipe (mm)	Diameter derivation (mm)	Heating time pipe (sec)	Heating time saddle (sec)	Holding time (sec)	Cooling time (min)
40	20	30	30	20	30
40	25	30	30	20	30
50	20	30	30	20	30
50	25	30	30	20	30
63	20	30	30	20	30
63	25	30	30	20	30
63	32	30	30	20	30
75	20	30	30	20	30
75	25	30	30	20	30
75	32	30	30	20	30
75	40	30	30	20	30
90	20	30	30	20	30
90	25	30	30	20	30
90	32	30	30	20	30
90	40	30	30	20	30
110	20	30	30	20	30
110	25	30	30	20	30
110	32	30	30	20	30
110	40	30	30	20	30
125	20	30	30	20	30
125	25	30	30	20	30
125	32	30	30	20	30
125	40	30	30	20	30
40	1/2"	30	30	20	30
40	3/4"	30	30	20	30
50	1/2"	30	30	20	30
50	3/4"	30	30	20	30
63	1/2"	30	30	20	30
63	3/4"	30	30	20	30
75	1/2"	30	30	20	30
75	3/4"	30	30	20	30
75	1"	30	30	20	30
90	1/2"	30	30	20	30
90	3/4"	30	30	20	30
90	1"	30	30	20	30
110	1/2"	30	30	20	30
110	3/4"	30	30	20	30
110	1"	30	30	20	30
125	1/2"	30	30	20	30
125	3/4"	30	30	20	30
125	1"	30	30	20	30

Approvals & Certificates

Certificate MY1401027

SGS

The management system of

George Fischer (M) Sdn. Bhd.
(Company No : 534801-X)

No. 14, Jalan Anggerik Mokara 3100
Section 31, Kota Kemuning
40460 Shah Alam, Selangor
MALAYSIA

has been assessed and certified as meeting the requirements of

ISO 9001:2008

For the following activities

Sales, Manufacturing and Provision of Technical Service of Piping System

Further certification against the scope of this certificate and the requirements of ISO 9001:2008 requirements may be obtained by notifying the registration

This certificate is valid from 13 December 2014 until 09 December 2017 and remains valid subject to satisfactory surveillance audits. The certification audit due before 11 October 2017 Issue 1. Certified since 10 December 2014

Authorised by





SGS (Malaysia) Sdn. Bhd. Systems & Services Certification
200, Jalan, Sungai Besi, No. 11, Jalan Sungai
Besi, Kuala Lumpur, 50450 Kuala Lumpur, Kuala Lumpur
F 03 - 3383 3333 F 03 - 3383 3333 www.sgs.com

MS ISO/IEC 17021:2011
CER 1812259-02 EN

Page 1 of 1



Certificate MY10800148

SGS

The management system of

George Fischer (M) Sdn. Bhd.
(Company No : 534801-X)

No. 14, Jalan Anggerik Mokara 3100
Section 31, Kota Kemuning
40460 Shah Alam, Selangor
MALAYSIA

has been assessed and certified as meeting the requirements of

ISO 14001:2004

For the following activities

Sales, Manufacturing and Provision of Technical Service of Piping System

This certificate is valid from 21 November 2014 and 20 November 2017 and remains valid subject to satisfactory surveillance audits. The certification audit due before 20 September 2017 Issue 3. Certified since 21 November 2008

Authorising





SGS (Malaysia) Sdn. Bhd. Systems & Services Certification
200, Jalan, Sungai Besi, No. 11, Jalan Sungai
Besi, Kuala Lumpur, 50450 Kuala Lumpur, Kuala Lumpur
F 03 - 3383 3333 F 03 - 3383 3333 www.sgs.com

MS ISO/IEC 17021:2011
EMS 1807204-02 EN

Page 1 of 1



Certificate MY13101283

SGS

The management system of

George Fischer (M) Sdn. Bhd.
(Company No: 534801-X)

No. 14, Jalan Anggerik Mokara 3100
Section 31, Kota Kemuning
40460 Shah Alam, Selangor
MALAYSIA

has been assessed and certified as meeting the requirements of

OHSAS 18001:2007

Occupational Safety and Health Management Systems

For the following activities

Sales, Manufacturing and Provision of Technical Service of Piping System

Further certification against the scope of this certificate and the requirements of OHSAS 18001:2007 requirements may be obtained by notifying the registration

This certificate is valid from 05 August 2013 until 04 August 2016 and remains valid subject to satisfactory surveillance audits. The certification audit due before 02 July 2015 Issue 1. Certified since 05 August 2013

Authorised by





SGS (Malaysia) Sdn. Bhd. Systems & Services Certification
200, Jalan, Sungai Besi, No. 11, Jalan Sungai
Besi, Kuala Lumpur, 50450 Kuala Lumpur, Kuala Lumpur
F 03 - 3383 3333 F 03 - 3383 3333 www.sgs.com

MS ISO/IEC 17021:2011
CER 1812259-02 EN

Page 1 of 1



No. Lesen: P1028803
Lembar F01

SIRIM QAS

LESEN PENSIJILAN BARANGAN
Product Certification Licence



SIRIM QAS International Sdn. Bhd. dengan ini mengesahkan kepada SIRIM QAS International Sdn. Bhd. terasnya seperti ini:

GEORGE FISCHER (M) SDN. BHD.
NO. 14, JALAN ANGERIK MOKARA 3100
SECTION 31, KOTA KEMUNING
40460, SHAH ALAM
SELANGOR, MALAYSIA

Lesen untuk menggunakan Tanda Pensijilan di atas barangan
a licence to use the Certification Mark on
**POLYPROPYLENE(PP) PIPES FOR HOT AND COLD WATER
INSTALLATIONS**

Please refer to detail in the SCHEDULE

sebagai mematuhi keperluan
as complying with
ISO 15874-2 : 2005



Khairudin Mustafa
Pengerusi Urusan
Pengarah Director
Suruhan QAS International Sdn. Bhd.

<p>Suruhan QAS International Sdn. Bhd. No. 10, Jalan Sultan Ismail, 50450 Kuala Lumpur, Kuala Lumpur F 03 - 2091 6555 F 03 - 2091 6555 www.sgs.com</p>	<p>Tarikh Mulai Pensijsilan : 21 May 2010 Certified Since : 21 May 2010 Istiadat / Issue Date : 21 May 2010</p>	<p>Tarikh Tamat Pensijsilan : 03 April 2016 Valid Until : 03 April 2016 Tempoh / Validity : 216527</p>
--	---	--

Lesen ini mengesahkan bahawa pengesahan pengesahan Pensijilan Barangan SIRIM QAS International Sdn. Bhd. This Licence is granted subject to the approval of the Product Certification Approval of SIRIM QAS International Sdn. Bhd.

Approvals & Certificates

SIRIM QAS INTERNATIONAL
LESEN PENSIJILAN BARANGAN
Product Certification Licence

My Lesen: PG02902
 Lesen No: 1

SIRIM QAS International Sdn. Bhd. dengan ini mengemukakan kepada SIRIM QAS International Sdn. Bhd. hereby grants to:

GEORGE FISCHER (M) SDN BHD
 NO. 14, JALAN ANGGER MAKARA 2/08
 SEKTOR 31, KOTA KEMUNING
 68400, SHAH ALAM
 SELANGOR, MALAYSIA.

Lesen untuk menggunakan Tanda Pensiilan di atas barangan a license to use the Certification Mark on:

POLYPROPYLENE (PP) FITTINGS FOR HOT AND COLD WATER INSTALLATIONS

Please refer to detail in the SCHEDULE

sebagai mematuhi keperluan as complying with
 ISO 15674-3 : 2003

1. Chandraharan
 Khairul Anwar
 Managing Director
 SIRIM QAS International Sdn. Bhd.

Keahlian/Professional Title	Terima/Member	12 May 2015	Tawakul/Bachelor	12 August 2015
Keahlian/Professional Title	Keahlian/Member	12 May 2015	Keahlian/Member	12 May 2015
Keahlian/Professional Title	Keahlian/Member	12 May 2015	Keahlian/Member	12 May 2015

DNV

DET NORSKE VERITAS
 TYPE APPROVAL CERTIFICATE

CERTIFICATE NO. K-9023

This is to certify that the
 Plastic Pipes, Thermoplastics

with type designations:
 "-GF+ AQUASYSTEM (PP-R 20x11 (PN15) and 20x15 (PN20) Pipes and Fittings)

Issued to:
George Fischer (M) Sdn Bhd
 Shah Alam, Malaysia

is found to comply with
 Det Norske Veritas' Rules for Classification of Ships
 Det Norske Veritas' Type Approval Programme 1-901.3, 2011, Thermoplastic Pipes

Application:
 For use in systems for water and sea water up to 10 and 20 bar. Service temperature 0°C to 70°C (short period up to 95°C). For installation in accordance with DNV Rules and Manufacturer's Specifications. The piping system is tested to Low Flame Spread in accordance with ABS 106 DSA. The piping system is not tested w.r.t. Fire Endurance characteristics.

This Certificate is valid until 2017-02-01.

Issued at Havnk: 01/2014-08-08

DNV head office: Kuala Lumpur

Approved Engineer: **Qalei Harwin**

For Det Norske Veritas AS
 Classification Society

Maria Skovde
 Head of Section

Page 1 of 2

RECOGNITION FOR
 BV MODE II SCHEME

GEORGE FISCHER (M) SDN BHD
 SHAH ALAM SELANGOR - MALAYSIA

Summary of the scope of the recognition which is obtained in the subsequent pages:
 THERMOPLASTIC MATERIAL, PIPES AND FITTINGS

This certificate is issued to attest that the DET NORSKE VERITAS has authorized, at the above company's request and in compliance with the requirements of TMS 2, a substantial acquisition of the manufacturing facilities and machinery already productive relative to the scope of recognition.

This certificate will expire on: 15 May 2019

For GEORGE FISCHER (M) SDN BHD
 SHAH ALAM, MALAYSIA

For GEORGE FISCHER (M) SDN BHD
 SHAH ALAM, MALAYSIA

GL

Type Approval Certificate

This is to certify that the referenced product(s) has/have been tested in accordance with the relevant requirements of the GL Type Approval System.

Certificate No. 12-932 - 11-194

Company: **George Fischer (M) Sdn. Bhd.**
 No. 14, Jalan Angger Makara 2/08
 Sektor 31, Kota Kemuning
 68400 Shah Alam, MALAYSIA

Product Description: **THERMOPLASTIC PP-R AND FITTINGS**

Type: **HGF+ AQUASYSTEM**
 PP-R piping system

Environmental Category: None

Technical Data:
 Range of Application: 20 (wall up to 110 (wall)
 PN15, PN20
 Temperature range: 0 (°C) up to 70 (°C) (short period 95 (°C))
 (Indication of maximum allowable working pressure by service temperature above 20°C according to the specifications of the manufacturer.)

SCOPE OF APPLICATION:
 Hot and cold potable water, sanitary discharge, heating and spa water systems.
 With accessories, devices and control systems the piping system is to be protected by B-class or fully closed C-class coatings and fittings.

LIMITATION:
 This piping system is not approved for installation within tanks and open decks and for locations where a level of fire endurance is required. Refer to GL Rule 3-2 Machinery Installations, Section 11-1-10 and 11-1-11.

TEST STANDARD:
 V2-5 Test Requirements for Components and Systems of Mechanical Engineering (2006, revised 1st and 2nd editions, validity: under revision)

Documents:
 - Product catalogue GF_MV2008(4)(15)
 - Visit test report, typical pressure tests, impact test, DNV approval test, etc. to AUST 2130
 - GL Approval Reference No.: 11-00007, 12-61970

Remarks:
 For the use on passenger vessels national authority requirements may have to be observed.

Valid until: 2017-02-01

Page: 1 of 2

File No.: 6-034

Hamburg: 2013-02-15

Germanischer Lloyd
 Hans-Joerg Beyer
 Hans-Joerg Beyer
 Hans-Joerg Beyer

General Condition of Supply of Georg Fischer Piping Systems Limited, Schaffhausen

1	General	11	Packing
1.1	These General Conditions shall apply to all Products supplied by Georg Fischer to the Purchaser. They shall also apply to all future business even when no express reference is made to them.		If the Products are provided with additional packing over and above the standard packing, such packing shall be charged additionally.
1.2	Any deviating or supplementary conditions especially Purchaser's general conditions of purchase and verbal agreements shall only be applicable if accepted in writing by Georg Fischer.	12	Passing of Risk
1.3	The written form shall be deemed to be fulfilled by all forms of transmission, evidenced in the form of text, such as telefax, e-mail, etc.	12.1	The risk in the Products shall pass to the Purchaser as soon as they have left Georg Fischer's works (EX WORKS, Incoterms ICC, latest version), even if delivery is made carriage-paid, under similar clauses or including installation or when carriage is organized and managed by Georg Fischer.
2	Tenders	12.2	If delivery is delayed for reasons beyond Georg Fischer's control, the risk shall pass to the Purchaser when he is notified that the Products are ready for despatch.
	Tenders shall only be binding if they contain a specifically stated period for acceptance.	13	Carriage and Insurance
3	Scope of Delivery	13.1	Unless agreed otherwise, the Purchaser shall bear the cost of carriage.
3.1	Georg Fischer's product range is subject to change.	13.2	The Purchaser shall be responsible for transport insurance against damage of whatever kind. Even when such insurance is arranged by Georg Fischer it shall be deemed taken out by the order of and for the account of the Purchaser and at his risk.
3.2	The confirmation of order shall govern the scope and execution of the contract.	13.3	Special requests regarding carriage and insurance shall be communicated to Georg Fischer in due time. Otherwise carriage shall be arranged by Georg Fischer at their discretion, but without responsibility, by the quickest and cheapest method possible.
4	Data and Documents	13.4	In case of carriage-paid delivery transport arrangements shall be made by Georg Fischer. If the Purchaser specifies particular requirements, any extra costs involved shall be borne by him. In the event of damage or loss of the Products during carriage the Purchaser shall mark the delivery documents accordingly and immediately have the damage ascertained by the carrier. Not readily ascertainable damages sustained during carriage shall be notified to the carrier within six days after receipt of the Products.
4.1	Technical documents such as drawings, descriptions, illustrations and data on dimensions, performance and weight as well as the reference to standards are for information purposes only. They are not warranted characteristics and are subject to change.	14	Inspection, Notification of Defects and Damages
4.2	All technical documents shall remain the exclusive property of Georg Fischer and may only be used for the agreed purposes or as Georg Fischer may consent.	14.1	The Products will be subject to normal inspection by Georg Fischer during manufacture. Additional tests required by the Purchaser shall be agreed upon in writing and shall be charged to the Purchaser.
5	Confidentiality, Protection of Personal Data	14.2	It shall be a condition of Georg Fischer's obligation under the warranties stated hereinafter that Georg Fischer be notified in writing by the Purchaser of any purported defect immediately upon discovery. Notice concerning weight, numbers or apparent defects is to be given latest within 30 days from receipt of the Products, notice of other defects immediately latest within 7 working days after discovery, in any event within the agreed warranty period.
5.1	Each party shall keep in strict confidence all commercial or technical information relating to the business of the other party, of which it has gained knowledge in the course of its dealing with the other party. Such information shall neither be disclosed to third parties nor used for other purposes than those for which the information has been supplied.	14.3	Purchaser shall not dispose of allegedly defective Products until all warranty and/or damage claims are finally settled. At its request, defective Products are to be placed at Georg Fischer's disposal.
5.2	In the context of the contractual relation with the Purchaser personal data may be processed. The Purchaser agrees to the disclosure of said data to third parties such as foreign subcontractors and suppliers etc.	14.4	At its request, Georg Fischer shall be given the opportunity to inspect the defect and/or damage, prior to commencement of remedial work, either itself or by third party experts.
6	Local Laws and Regulations, Export Controls	15	Warranty
6.1	The Purchaser shall bring to the attention of Georg Fischer all local laws and regulations at the place of destination which bear connection with the execution of the contract and the adherence to relevant safety regulations and approval procedures.	15.1	At the written request of the Purchaser, Georg Fischer undertake to repair or replace at their discretion, as quickly as possible and free of charge all Products supplied which demonstrably suffer from faulty design, materials or workmanship or from faulty operating or installation instructions.
6.2	In case of re-exports, Purchaser shall be responsible for compliance with pertinent export control regulations.		In order to protect employees from toxic or radioactive substances which may have been transported through defective parts returned to Georg Fischer's sales organisation, said parts must be accompanied by a Material Safety Disclosure Form. The form may be obtained from Georg Fischer's local sales company or via www.piping.georgfischer.com . Replaced parts shall become property of Georg Fischer, unless Georg Fischer waives such claim.
7	Price	15.2	For Products which are manufactured to specifications, drawings or patterns supplied by the Purchaser, Georg Fischer's warranty shall be restricted to proper materials and workmanship.
7.1	Unless agreed otherwise, the prices shall be deemed quoted net ex works (according to Incoterms of the ICC, latest version) including standard packing. All supplementary costs such as the cost of carriage, insurance, export-, transit- and import- licences etc. shall be borne by the Purchaser. The Purchaser shall also bear the costs of all taxes, fees, duties etc. connected with the contract.	15.3	The Purchaser shall be entitled to cancel the contract or to demand a reduction in the contract price if also a second attempt to repair or replace the Products has failed.
7.2	If the costs of packing, carriage, insurance, fees and other supplementary costs are included in the tender price or contract price or are referred to specifically in the tender or confirmation of order, Georg Fischer reserve the right to revise their prices accordingly should any change occur in the relevant tariffs.	15.4	For Products or essential components manufactured by a third party and supplied by Georg Fischer under this contract, Georg Fischer's warranty is limited to the warranty provided by said third party.
8	Terms of Payment	15.5	This warranty shall not apply to damage resulting from normal wear and tear, improper storage and maintenance, failure to observe the operating instructions, oversteering, overloading, unsuitable operating media, unsuitable construction work or unsuitable building ground, improper repairs or alterations by the Purchaser or third parties, the use of other than original spare parts and other reasons beyond Georg Fischer's control.
8.1	The Purchaser shall make payment in the manner agreed by the parties without any deductions such as discounts, costs, taxes or dues.	15.6	No action or claim may be brought by the Purchaser on account of any alleged breach of warranty or any other obligation of Georg Fischer after the expiration of twelve (12) months from receipt of the Products by the end user or at the latest within eighteen (18) months of the Products being despatched by Georg Fischer.
8.2	The Purchaser may only withhold or off-set payments due against counter claims which are either expressly acknowledged by Georg Fischer or finally awarded to the Purchaser. In particular, payment shall still be made when unessential items are still outstanding provided that the Products already delivered are not rendered unusable as a result.	15.7	In case of Products for use in domestic installations or in utilities - Georg Fischer will assume the costs of dismantling the defective Product and restoring the damaged object as well as, in case of negligence, all other direct damages caused by the defective Product (damage to property and injury to or death of persons) up to CHF 1'000'000 per occurrence. - the statute of limitations for warranty or damage claims - contrary to Section 15.6 - will be 5 years from the date of installation.
9	Retention of Title	16	Limitation of Liability
9.1	The Products shall remain the property of Georg Fischer until the Purchaser shall have settled all claims, present and future, which Georg Fischer may have against him.		All cases of breach of contract and the relevant consequences as well as all rights and claims on the part of the customer, irrespective on what ground they are based, are exhaustively covered by these general conditions of supply. In particular, any claims not expressly mentioned for damages, reduction of price, termination of or withdrawal from the contract are excluded. In no case whatsoever shall the customer be entitled to claim damages other than compensation for costs of remedying defects in the supplies. This in particular refers, but shall not be limited, to loss of production, loss of use, loss of orders, loss of profit and other direct or indirect or consequential damage. This exclusion of liability, however, does not apply to unlawful intent or gross negligence on the part of Georg Fischer and in case of strict liability under applicable product liability statutes, but does apply to unlawful intent or gross negligence of persons employed or appointed by Georg Fischer to perform any of its obligations.
9.2	Should the Purchaser resell Products to which title is reserved, in the ordinary course of business, he shall hereby be deemed to have tacitly assigned to Georg Fischer the proceeds deriving from their sale together with all collateral rights, securities and reservations of title, until all claims held by Georg Fischer shall have been settled. Until revoked by Georg Fischer, this assignment shall not preclude Purchaser's right to collect the assigned receivables.	17	Severability
9.3	To the extent the value of the Products to which title is reserved together with collateral securities exceeds Georg Fischer's claims against the Purchaser by more than 20%, Georg Fischer shall re-assign the above proceeds to Purchaser at his request.		Should any term or clause of these General Conditions in whole or in part be found to be unenforceable or void, all other provisions shall remain in full force and effect and the unenforceable or void provision shall be replaced by a valid provision, which comes closest to the original intention of the unenforceable or invalid provision.
10	Delivery	18	Place of Performance and Jurisdiction
10.1	The term of delivery shall commence as soon as the contract has been entered into, all official formalities such as import and payment permits have been obtained and all essential technical issues have been settled. The term of delivery shall be deemed duly observed when, upon its expiry, the Products are ready for despatch.	18.1	Place of performance for the Products shall be the Georg Fischer works from which the Products are despatched.
10.2	Delivery is subject to the following conditions, i.e. the term of delivery shall be reasonably extended:	18.2	Any civil action based upon any alleged breach of this contract shall be filed and prosecuted exclusively in the courts of Schaffhausen, Switzerland. Georg Fischer however reserves the right to file actions in any court having jurisdiction over controversies arising out of or in connection with the present contract.
a)	If Georg Fischer are not supplied in time with the information necessary for the execution of the contract or if subsequent changes causing delays are made by the Purchaser.	18.3	The contract shall be governed by Swiss law without regard to conflict of law provisions that would require the application of another law.
b)	If Georg Fischer are prevented from performing the contract by force majeure. Force majeure shall equally be deemed to be any unforeseeable event beyond Georg Fischer's control which renders Georg Fischer's performance commercially unpractical or impossible, such as delayed or defective supplies from sub contractors labour disputes, governmental orders or regulations, shortages in materials or energy, serious disturbances in Georg Fischer's works, such as the total or partial destruction of plant and equipment or the breakdown of essential facilities, serious disruptions in transport facilities, e.g. impassable roads. Should the effect of force majeure exceed a period of six months, either party may cancel the contract forthwith. Georg Fischer shall not be liable for any damage or loss of any kind whatsoever resulting therefrom, any suspension or cancellation being without prejudice to Georg Fischer's right to recover all sums due in respect of consignments delivered and costs incurred to date.		
c)	If the Purchaser is in delay with the fulfilment of his obligations under the contract, in particular, if he does not adhere to the agreed conditions of payment or if he has failed to timely provide the agreed securities.		
10.3	If for reasons attributable to Georg Fischer the agreed term of delivery or a reasonable extension thereof is exceeded, Georg Fischer shall not be deemed in default until the Purchaser has granted to Georg Fischer in writing a reasonable extension thereof of not less than one month which equally is not met. The Purchaser shall then be entitled to the remedies provided at law, it being however understood that, subject to limitations of Art. 16, damage claims shall be limited to max. 10% of the price of the delayed delivery.		
10.4	Part shipments shall be allowed and Georg Fischer shall be entitled to invoice for such partial deliveries.		
10.5	If the Purchaser fails to take delivery within a reasonable time of Products notified as ready for despatch, Georg Fischer shall be entitled to store the Products at the Purchaser's expense and risk and to invoice them as delivered. If Purchaser fails to effect payment, Georg Fischer shall be entitled to dispose of the Products.		
10.6	Should Purchaser cancel an order without justification and should Georg Fischer not insist on the performance of the contract, Georg Fischer shall be entitled to a penalty amounting to 10% of the contract price, Georg Fischer's right to prove and claim higher damages remaining reserved. Purchaser shall be entitled to prove, that Georg Fischer has suffered no or a considerably lower damage than the penalty forfeited.		

Worldwide at home

Our sales companies and representatives ensure local customer support in over 100 countries.



www.gfps.com

The technical data are not binding. They neither constitute expressly warranted characteristics nor guaranteed properties nor a guaranteed durability. They are subject to modification. Our General Terms of Sale apply.



Quality Management System certified according ISO 9001:2008



Environmental Management System certified according ISO 14001:2004



Occupational Safety and Health Management Systems certified according OHSAS 18001:2007



Malaysia / Export

George Fischer (M) Sdn. Bhd. (534801-X)
No. 2, 4 & 6, Jalan Permata 3/KS 09,
Taman Perindustrian Air Hitam,
41200 Klang, Selangor Darul Ehsan,
Malaysia
Tel : +603 3122 5585
Fax : +603 3122 5575
www.gfps.com/my

Malaysia Northern Region Sales & Service Centre

80-G & 80-1, Lintang Sungai Pinang, Skyline City,
10150 Georgetown, Penang,
Malaysia
Tel : +604 283 5575 / 6575
Fax : +604 283 2575

Malaysia Southern Region Sales & Service Centre

No.6, Jalan Ekoperniagaan 1/15,
Taman Ekoperniagaan,
81100 Johor Bahru, Johor DT,
Malaysia
Tel : +607 522 4222
Fax : +607 522 4333

Singapore *

George Fischer Pte. Ltd.
11 Tampines Street 92, #04-01/07,
528872 Singapore
Tel : +65 6747 0611
Fax : +65 6747 0577
www.gfps.com/sg

Indonesia

PT Georg Fischer Indonesia
Karawang - Factory
Jl. Desa Anggadita Klari,
Karawang Timur,
41371 Jawa Barat,
Indonesia
Tel : +62 267 432 044
Fax : +62 267 431 857
www.gfps.com/id

Surabaya - Office
Jl. Raya Gilang No.33, Taman,
Sidoarjo - 61257,
Indonesia
Tel : +62 31 788 1989

Bali - Office
Jl. Raya Cargo (Mahendradatta) No.63x Kav.B,
Pemecutan, Denpasar Utara,
Denpasar, Bali - 80116,
Indonesia
Tel : +62 811 1144 036

Philippines

George Fischer Pte. Ltd.
Philippines Representative Office
#3 E. Rodriguez Jr. Avenue,
Bagong Ilog (C5) Pasig City,
1604 Philippines
Tel : +632 571 2365 to 67
Fax : +632 571 2368
www.gfps.com/ph

Vietnam

George Fischer Pte. Ltd.
Vietnam Representative Office
Centre Point Building, Room 601,
Floor 6, 106 Nguyen Van Troi Street,
Ward 8, Phu Nhuan District,
Ho Chi Minh City,
Vietnam
Tel : +84 28 3948 4000
Fax : +84 28 3948 4010
www.gfps.com/vt

* Thailand, Cambodia, Myanmar, Laos,
Brunei and East Timor / Timor-Leste